

# STICKLEY®

MISSION



AMERICAN ARTS & CRAFTS FURNITURE



# Contents

INSPIRATION .....	8-57
LIVING ROOMS .....	58-87
DINING ROOMS .....	88-101
BEDROOMS .....	102-115
HOME OFFICE .....	116-122
ACCESSORIES .....	123-129
PASADENA BUNGALOW .....	130-145
STICKLEY STARTERS .....	146-151
FINISHES .....	152-153
INDEX ROOM SCENES .....	156-158
INDEX NUMERIC .....	159

# FROM OUR FAMILY TO YOURS



LEFT TO RIGHT: Alfred Audi, Aminy Audi, Edward Audi, Andrea Audi and Carolyn Audi Fischi

Dear Friends,

We are very pleased to share with you the new Mission Collection Catalog. This catalog, the latest in a long line stretching back to the 1900's, is a testament to the continued relevance and versatility of Stickley's original American Arts & Crafts furniture designs. Designs that have shown their capacity to abide and contribute to a sense of beauty, comfort, and good living.

In the pages of this catalog, you will find many reissued Stickley designs, as practical and useful today as when conceived over a hundred years ago, alongside many newly designed pieces with today's homes and lifestyles in mind. New pieces like the patented Gathering Islands and entertainments units, with the look and feel of classic Arts & Crafts furniture and with practical additions such as power-strips and USB charging connections.

Whether it's a new or reissued piece, these treasures are all still handcrafted in a Stickley workshop from solid American quartersawn white oak or cherry. Using unique construction features such as tenons, side-hung and center-guided drawers, quadrilinear posts and blind dovetailed cross rails.

Along with its traditional craftsmanship, Stickley is renowned for hand-applied and hand-rubbed finishes. Finishes that produce the deep luster on each piece and take many hours of work by expert craftsmen and craftswomen. We are therefore pleased to include for the first time in this catalog a range of new Modern Oak finishes; Onyx, Lodge, Sand, and Fieldstone. These strikingly new finishes give the Mission collection furniture a new and unexpected look, greatly expanding the versatility and the types of home and home décor that it can be used to create.

May you find in this catalog the inspiration you seek to create your dream home. If you have not already discovered the magic of Stickley, we hope we can soon count you amongst the ever-growing number of people who have discovered the pleasure and pride in owning Stickley Arts & Crafts furniture. If you are among the four generations who have been investing in Stickley, we thank you on behalf of our family and our very talented Stickley team. May these beautiful furnishings contribute to enhancing your family gatherings and may your homes be filled with beauty, warmth and magical moments.

Yours Sincerely,

Aminy I. Audi  
CEO & Chairman of the Board

Edward J. Audi  
President



The shopmark—"Als Ik Kan,"  
"To the best of my ability"  
has always been Stickley's  
guiding principle.

# THE STICKLEY DIFFERENCE

Honesty and integrity of construction are essential tenets of Arts & Crafts furniture. The tried and tested traditional joinery that makes it strong and long-lasting is also a visible part of the intrinsic beauty of the furniture.

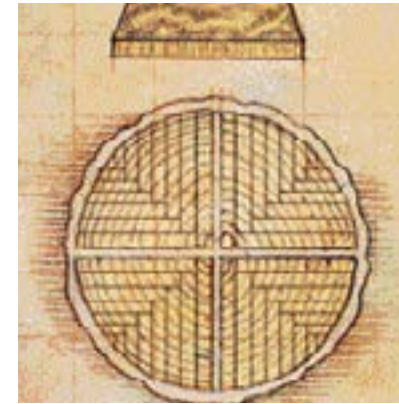

### Quartersawn White Oak

Oak, sawn parallel to the medullary rays is known as quarter-sawn, this type of cut produces boards of exceptional strength and reveals the prized ray flake patterning of oak that makes each piece of furniture unique.

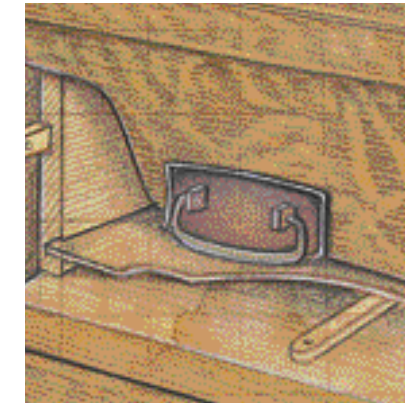

### Side-hung and Center-guided Drawers

In this traditional method of installing drawers, the center guide stops the drawer skewing and side suspension keeps the draws level when fully loaded. Each hand-fitted and numbered drawer will continue to open and close with ease.

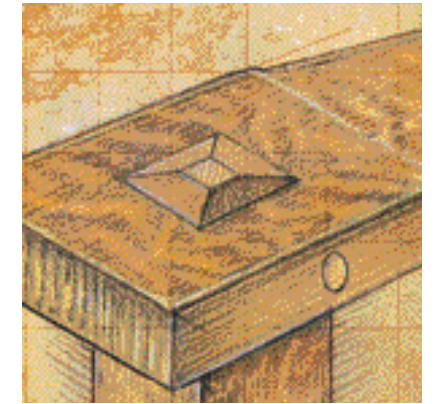

### Quadrilinear Posts

This technique allows the beauty of ray flake to appear on all four sides of a post, rather than on just the normal two. To achieve this, four quartersawn boards are mitered together around a solid core, increasing the strength and beauty of the post.

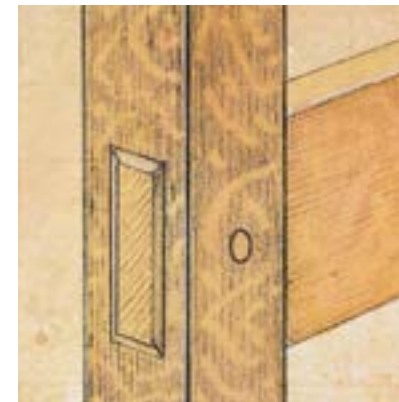

### Tenons

The key to Arts & Crafts furniture quality and durability, are mortise and tenon joints, a single Stickley chair can have over 30 such joints. A blind tenon is concealed within the mortise. While in a through tenon (shown above) the end of the tenon is visible and part of the form of the piece.

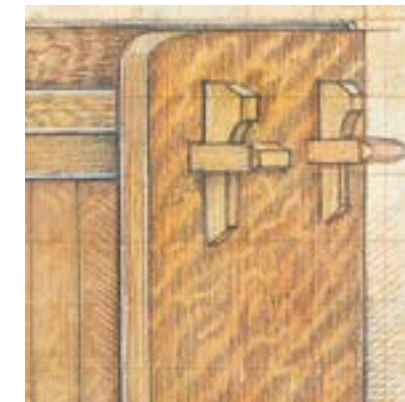

### Keyed Tenons

This distinctive form of tenon found in Arts & Crafts furniture uses a wedge shaped "key" inserted in to a tenon that pass through the side of a board to secure it in place. This traditional and highly effective mechanical joint gives exceptional strength and rigidity to the furniture.

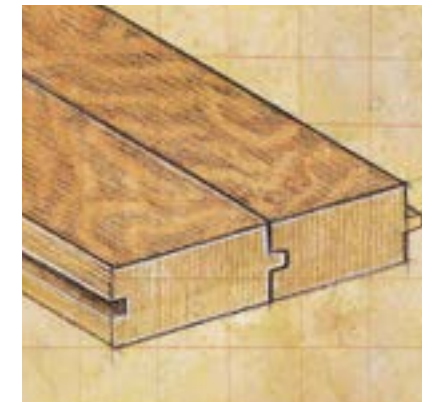

### Tongue and Groove Joints

This technique ensures accurate board alignment and gives individual matched boards the look of a solid piece of wood.

# A GREAT AMERICAN HISTORY



Left to right: John George, Leopold, Albert, Gustav and Charles Stickley

Als Ik Kan – “to the best of my ability” – has always been Stickley’s guiding principle. The old Flemish craftsmen’s phrase was marked right on the product in the early years, to assure customers that every piece of Stickley furniture was made with skill, determination, and integrity.

In the early 1900s, the Stickley brothers burst into international prominence. Their bold new Arts & Crafts designs were based on the notion that furniture should be “honest” – a reaction against the fake joinery, unnecessary gaudiness, and the shoddy workmanship of many of the pieces created in the early days of industrial furniture making.

The Stickley’s insisted on top-quality construction. Emphasis was placed on letting the organic beauty of quartersawn oak and other natural materials speak for themselves. The brothers also showed a genius for design, creating hundreds of new forms that were at once beautiful, practical, and exceedingly strong and long-lasting.

Stickley furniture suited the new ways American families wanted to live. Gustav Stickley made it his goal “to place within the reach of the middle class purchaser articles of practical use which are at the same time works of art.” Attractive, convenient, and affordable Arts & Crafts designs thus became accessible to everyday families. “Mission” became one of the first truly American styles.

Stickley furnishings represented sturdy straightforward construction, relying on the intrinsic beauty of natural raw materials, carefully balanced proportions, intelligent architectural design, and fine detailing to create visual pleasure.

As society became more industrial, crowded, and busy, Gustav Stickley prescribed simple and sincere

designs as an antidote. He preached the centrality of family and home life, and he argued that the structure of a home could shape its inhabitants. He made it his aim, often in league with his brothers, to produce beautiful household objects “at once useful, practical, and capable of speaking to the heart.”

Leopold and John George Stickley added a practical genius for Gustav’s aesthetic vision. After years of on-and-off collaboration and competition, the brothers joined forces in 1916. From that point forward, Leopold took the lead.

As design tastes changed, Leopold Stickley adapted, and in the 1920s he created the Cherry Valley Collection. The furniture was American colonial, crafted with the same uncompromised quality as the earlier Mission line. He took full advantage of the beauty and durability of the wild black cherry wood that was abundant in the Adirondack region. Stickley continued to elevate craftsmanship in this period, improving upon what had already been a stellar reputation for construction quality. In 1956 Leopold Stickley was named “Revered Dean of Cabinetmakers whose art and craftsmanship have contributed mightily to American home life,” by a group of notable publishers from House Beautiful, The New Yorker, National Geographic, Holiday, House & Garden, Fortune, The American Home, Living for Young Homemakers, Town & Country, and Better Homes & Gardens.

At the time of Leopold’s death in 1957, L. & J.G. Stickley was one of the most respected and admired furniture companies in the nation. Leopold’s widow, Louise, aided by many of the founder’s original staff, continued the tradition, insisting that all aspects of quality manufacturing be preserved.

# ROOTED IN THE PAST DESTINED FOR THE FUTURE.



Alfred J. Audi & Aminy I. Audi

“The idea of preserving a great company with great American tradition was very appealing to me.”

Alfred J. Audi



Edward Audi

During the 1960s and 1970s, as many of the original craftsmen retired, the Stickley company faced an uncertain future. A new era began in 1974, when Alfred and Aminy Audi bought the company, its humble factory and a mere two dozen workers. Together, they nurtured it back to health. The skilled, veteran cabinetmakers taught a new generation of craftspeople how Stickley furniture is to be made. The Audis then turned their attention to marketing the product and to surrounding themselves with a winning team of knowledgeable experts who share the same pride in the product and the same deep admiration for this very special furniture.

In 1985, Stickley moved down the road a few miles to a brand-new factory in Manlius, New York. This set the stage for the historic Mission Collection, reissued in 1989 and sparking unprecedented growth for Stickley. Two years later, Stickley unveiled Mission Cherry, a refreshing merger of the most identifiable Stickley designs and the wood species Stickley used for decades. In 1996, the Stickley Fine Upholstery & Leather factory opened in High Point. It later moved to this modern facility in 2000.

Stickley’s U.S. factories have undergone numerous expansions in recent years. The main New York factory now has over 400,000 square feet of efficient space and state-of-the-art technology. More than thirty languages are spoken in the Manlius factory, as the legacy of Italian, English, German and Hungarian immigrants who worked at Stickley decades ago are honored by craftspeople from five continents and over thirty nationalities.

In its efforts to be globally competitive, Stickley opened a high-tech production facility in Vietnam in 2005. One of the largest immigrant groups in the Upstate New York factory is Vietnamese. In fact,

several dozen of Stickley’s New York employees returned to Vietnam to work at the new facility and reconnect with their families in Vietnam.

Well over a hundred years have passed, but the spirit of the phrase “Als Ik Kan” still resonates from Stickley’s authentic, impeccable crafted furniture. The company’s focus on quality, design and construction remains the same today as when the Stickley company began. Today a new chapter is being written in the history of this venerable company under the leadership of its current President, Edward Audi along with the most talented and dedicated team, Stickley’s future looks very vibrant.



The present Stickley factory in Manlius, New York



Highlands Entertainment Unit featuring Gathering Island, Sectional Sofa & Chair.



Highlands Sofa, Chair & Cocktail Ottoman.



Highlands Writing Desk and Mackintosh Arm Chair.



Mission Great Room featuring Orchard Street Sofa, Bustle Back Bow Arm Morris Recliner and Highlands Dining Table.





Living Room with Settle and Gus Rocker.



Living Room featuring Entertainment Unit, Gathering Island and Chicago Sectional Sofa.



Gathering Island and Park Ridge Sofa.



Mission Living Room featuring  
Slat Back Settle & Chair.



Mission Great Room in Sand Modern Oak Finish.



Spindle Morris Chair from original 1905 patented  
Gustav Stickley Design.



Eastwood Arm Chair original 1902 Stickley No. 2638.



Highlands Occasional in Fieldstone Modern Oak Finish with Fargo Sofa.





Round Pedestal Dining Table.



Keyhole Trestle Table.



Harvey Ellis Dining Table and Chairs.



Highlands Trestle Table.



Highlands Double Pedestal Table.



Grande Trestle Table, Tall Back Upholstered Chairs,  
Syracuse Sideboard and Park City Wing Chair.



Highlands Round Dining Table.



Highlands Bedroom.





Highlands Platform Storage Bed.



Upholstered Highlands Bed in Fieldstone Modern  
Oak Finish.



Prairie Bed



Harvey Ellis Bed



Prairie Bed

89 - Solid Quartersawn White Oak  
91 - Solid Cherry

SOFAS & CHAIRS



LS

**Settle with Back Cushion**  
89-208 H29½ W77½ D34



LS•CH

**Harvey Ellis Settle**  
89-214 H30 W76 D32



**Slat Back Settle**  
89-1263 H39½ W83½ D36



SL•LS

**Orchard St. Sofa**  
89/91-9236-82 W82 D37 H34



LS•CH

**Prairie Settle**  
89/91-220 H29 W84½ D37½



LS•CH

**Harvey Ellis Settle Loose Cushion**  
89-214-LC H30 W76 D32



SL•LS

**Fayetteville Sofa**  
89-9234-82 W82 D37 H34



**Highlands Sofa**  
89/91-9800-88 W88 D38½ H33½



LS•CH

**Prairie Spindle Settle**  
89-234 H29½ W84½ D37½



**Spindle Settee**  
89-286 H49 W48½ D24½

SL-sleeper sofa LS-loveseat CH-chair



**Highlands Sectional**  
89/91-9800

SL-sleeper sofa LS-loveseat CH-chair



**Highlands Chair**  
89/91-9800-CH W30¼ D38½ H33½



**Highlands High Back Chair**  
89/91-9800-CH-HB W30¼ D38½ H37¾



**Gus Lounge Chair**  
89-1324 H39 W30 D32



**Gus Lounge Chair Loose Cushion**  
89-1324-LC H39 W30 D32



**Limbert Cafe Chair**  
89-1500 H34 W26 D22



**Highlands Ottoman**  
89/91-9800-OT W22½ D19¾ H16¼



**Highlands Cocktail Ottoman**  
89/91-9800-COT W61½ D31½ H17½



**Lounge Chair**  
89-2590 H39 W32 D34½



**Footstool**  
89/91-2591 H15½ W22 D16½



**Soho Footstool**  
89-532 H15½ W15 D18



**Highlands Recliner**  
89/91-989-RL H40 W31 D39¾



**Eastwood Chair**  
89-2638 H36 W36 D35¼



**Eastwood Footstool**  
89-1725 H16½ W24 D17



**Harvey Ellis Settee, with Inlay**  
89/91-357 H44 W44 D23½



**Spindle Morris Chair**  
89/91-369 H40 W33¾ D37½



**Spindle Morris Chair with Loose Cushion**  
89/91-369-LC H40 W33¾ D37½



Crafted with or without casters.

**Footstool**  
89/91-395 H15 W19 D15



**Spindle Morris Recliner Bustle Back**  
89/91-369-RL H40 W33¾ D39



**Gus Bow Arm Morris Chair**  
89/91-2340 H39 W30½ D36½



**Footstool**  
89-302 H5 W12½ D12½



**Bow Arm Morris Chair**  
89/91-406 H40 W35¾ D40



**Bow Arm Morris Chair Loose Cushion**  
89/91-406-LC H40 W35¾ D40



**Footstool**  
89/91-495 H15 W19 D15



**Bow Arm Morris Recliner Bustle Back**  
89/91-406-RL H40 W34¾ D40½



**Harvey Ellis Cube Chair**  
89-326 H29 W26½ D29



**Harvey Ellis Cube Chair Loose Cushion**  
89-326-LC H29 W26½ D29



**Compact Spindle Morris Chair**  
89/91-367-LC H39 W28½ D37½



**Slatted Morris Chair Loose Cushion**  
89-410-LC H40 W33 D37½



**Slatted Morris Chair**  
89-410 H40 W33 D37½



**Bow Arm Morris Recliner Straight Back**  
89/91-406-RL-S H40 W35¾ D40½



**Prairie Chair**  
89/91-416 H29 W42½ D37½



**Prairie Spindle Chair**  
89-417 H29½ W42½ D37½





ROCKING CHAIRS



**Harvey Ellis Shoe Foot Rocker**  
89-327-A-R H45 W23 D31



**Harvey Ellis Rocker, with Inlay**  
89/91-353-A-R H43 W26 D31½



**Harvey Ellis Rocker, no Inlay**  
89/91-354-A-R H43 W26 D31½



**Spindle Rocker**  
89-376-R H45 W28 D31



**Rocker**  
89/91-401-R H40 W33 D41



**Loose Cushion Rocker**  
89/91-401-R-LC H40 W33 D41



**Chapel Street Rocker**  
89/91-837-R H40½ W28 D29½



**Gus Rocker**  
89-1324-R H39 W30 D32



**Loose Cushion Gus Rocker**  
89-1324-R-LC H39 W30 D32

Personalize the look and functionality of your home theater experience with solid quartersawn white oak or wild black cherry in a variety of hand rubbed finishes. Select either stand-alone cabinets or modular units that all feature wire access and quick release back panels. Modular cabinets cannot be bunched together because of through tenons on the side.

**Large Bridge & Shelf**  
89/91-1175 H4 W73 D17

**TV Backboard**  
89/91-1178 H47 W62 D2

**Bookcase Unit (L/R options)**  
89/91-1176 H76 W24 D17



Create an entertainment center that suits your needs and décor. To a console, you can add right and left shelf-units as needed, use a bridge to create a full unit by linking the shelves at the top.



**50" TV Console**  
89/91-1170 H28 W50 D22



**68" TV Console**  
89/91-1171 H28 W68 D22



**44" TV Console**  
89/91-1172 H28 W43½ D22



**62" TV Console**  
89/91-1173 H28 W61½ D22



**50" TV Console**  
89/91-1180 H28 W50 D22



**68" TV Console**  
89/91-1181 H28 W68 D22



**44" TV Console**  
89/91-1182 H28 W43½ D22



**62" TV Console**  
89/91-1183 H28 W61½ D22



**50" Harvey Ellis TV Console**  
89/91-1190 H28 W50 D22



**68" Harvey Ellis TV Console**  
89/91-1191 H28 W68 D22



**44" Harvey Ellis TV Console**  
89/91-1192 H28 W43½ D22



**62" Harvey Ellis TV Console**  
89/91-1193 H28 W61½ D22



**Bridge (shown with TV Console and Etagere)**  
89/91-1184 H3 W66 D16



**Harvey Ellis Entertainment Console**  
89/91-848 H32 W67 D14



Available with Wood, Glass or Speaker Doors

**Sliding Door TV Console**  
89-1150 H28½ W46½ D21



Also available in 48"

**TV Console**  
89/91-1185 H34 W66 D16



**Etagere**  
89/91-1186 H80 W30 D16



Available in any combination of Wood, Glass or Speaker doors

**Sliding Door TV Console**  
89-1151-WWW H28½ W68 D21



**Highlands Entertainment Console**  
89/91-1189 H40 W84 D16½



**Highlands Small Entertainment Console**  
89/91-1187 H32 W54 D15



Also available in 48"

**Highlands Entertainment Console**  
89/91-1188 H34 W66 D16



**Mission Entertainment Console**  
89-1199 H40 W84 D16½



**TV Sideboard**  
89-1901-E H40 W74½ D23



While some furniture takes up space, Stickley Exclusive Gathering Islands™ create it. And shared experiences just come with the territory. Fitting like a glove behind a variety of sofas, they provide plenty of space for personal treasures, a wide range of seating options, hand-crafted construction, and a built-in power strip!

## GATHERING ISLANDS



**Highlands 78" Gathering Island**

89/91-1708 H36 W78 D20¾ Also available in 58" and 90"

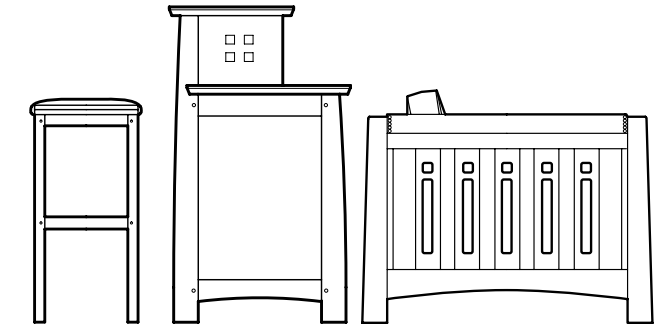

Designed for sofa back at 27.5"



**78" Gathering Island - Stone or Wood Top**

89/91-1712-ST H36 W78 D25 Also available in 90"

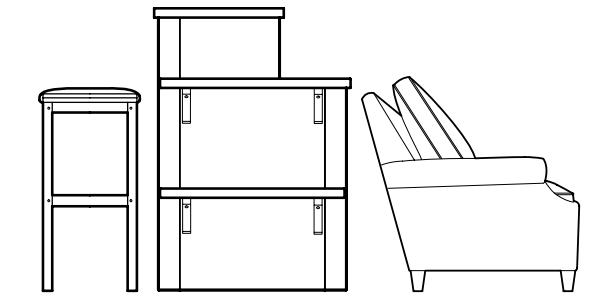

Designed for sofa back at 27"



**Tall 78" Gathering Island - Stone or Wood Top**

89/91-1715-ST H42 W78 D25 Also available in 90"

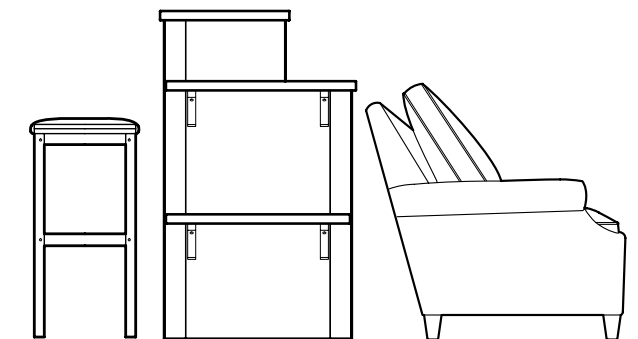

Designed for sofa back at 33"



STOOLS



Also available in Counter Stool option

**Backless Bar Stool**

89/91-105-B H30 W17 D17



Also available in Counter Stool option

**Bar Stool**

89/91-305-B H30 W19½ D15



Also available in Counter Stool option

**Swivel Bar Stool**

89/91-328-B H30¾ Dia 17¾



Also available in Counter Stool option

**Spindle Bar Stool**

89/91-321-B H45½ W18½ D21



Also available in Counter Stool option

**Slat Back Bar Stool**

89/91-322-B H45½ W18½ D21



Also available in Counter Stool option

**Leather Back Bar Stool**

89/91-322-B-LB H45½ W18½ D21



Also available in Bar Stool option

**Fleming Counter Stool**

89-7289-C H38 W18½ D20



COFFEE & COCKTAIL TABLES



Swivel Top option available

**Commemorative Coffee Table - Wood Top**  
89-411 H18 Dia 42



Swivel Top Leather option available

**Commemorative Coffee Table - Leather Top**  
89-411-LT H18 Dia 42



**Harvey Ellis Round Cocktail Table**  
89/91-479 H20 Dia 40



**Highlands Round Cocktail Table**  
89/91-982 H18 Dia 42



**Soho Footstool**  
89-532 H15½ W15 D18

**Cocktail Table**  
89-545-G/ST H19 W48 D38



**Butterfly Top Cocktail Table**  
89-578 H18 W39 D39



**Tile Top Cocktail Table**  
89-579 H18 W39 D39



**Cocktail Table**  
89-580 H19 W63 D39



**Tile Top Cocktail Table**  
89-581 H19 W63 D39

END TABLES



**Harvey Ellis Storage Cocktail Table**  
89/91-743 H19 W46 D26



**Harvey Ellis Storage Cocktail Table (SQ)**  
89-744 H19 W40 D40



**Three Drawer Cocktail Table**  
89/91-756 H18 W48 D22



**Grand Poppy Table**  
89/91-028 H28 Dia 26



**Gus Corner Table**  
89-434 H35½ W39 D27½



**End Table with Drawer**  
89/91-447 H24 W17 D26



**Cocktail Table**  
89-757 H17 W48 D22



**Tile Top Cocktail Table**  
89-758 H17½ W48 D23



**Glass Top Cocktail Table**  
89-759 H17½ W48 D22



**Harvey Ellis Round Lamp Table**  
89/91-470 H26 Dia 26



**Harvey Ellis Tea Table**  
89/91-475 H25 Dia 23



**Rectangular End Table**  
89-501 H26 W20 D26



**Cocktail Table**  
89-767 H17 W44 D36



**Highlands Cocktail Table**  
89/91-980 H18 W56 D34



**Highlands Square Cocktail Table**  
89/91-981 H18 W42 D42



**Drop Leaf Table**  
89/91-509 H24½ W8 D24



**Octagonal Table**  
89-515 H24 W20 D20



**Book Table**  
89-516 H29 W27 D27

END TABLES



**Round Lamp Table**  
89-536 H26 Dia 26



**Harvey Ellis Nesting Tables**  
89/91-537 H25½ W25 D18



**Tier Table**  
89/91-547 H26 W20½ D14



**Highlands Oval End Table**  
89/91-983 H26 W30 D23



**Highlands End Table**  
89/91-984 H26 W22 D28



**Gus Tea Table**  
89-1005 H24 Dia 24



**Butterfly Top End Table**  
89-576 H26½ W24 D20½



**Tile Top End Table**  
89-577 H26½ W24 D20½



**Round Table**  
89-663 H28½ Dia 29



**Gus Plant Stand**  
89-1041 H26 W14 D14



**Gus Round Lamp Table**  
89-1410 H26 Dia 27



**Round Table**  
89-1411 H30 Dia 36



**Round End Table**  
89-664 H24 Dia 26



**End Table**  
89/91-746 H23 W21½ D26



**Lamp Table**  
89/91-747 H26½ W28 D28



**Argyle Street End Table**  
89-8784 H26 W24 D24



**Tile Top Stand**  
89-048 H26 W14½ D14½



TABOURET TABLES



**Roycroft Tabouret Table**  
89/91-049 H20 W14 D14



**Roycroft Tabouret**  
89/91-050 H20½ W16 D16



**Wood Top Tabouret Table**  
89-051 H22 W17 D17



**Tile Top Tabouret Table**  
89-052 H22 W17 D17



**Limbert Pedestal**  
89-240 H29 W20 D20



**Limbert Tabouret Table**  
89/91-334 H18 W16 D16



**Gus Tile Top Tabouret**  
89-546 H21 W19 D19



**Round Tabouret Table**  
89/91-603 H20 Dia 18



**Highlands Tabouret**  
89/91-987 H18 W16 D16

CONSOLES



**Harvey Ellis Door Console**  
89/91-847 H30 W38 D13



**Sofa Table**  
89/91-857 H28½ W54 D16



**Console Table**  
89-858 H28½ W38 D13



**Two Door Console**  
89-859 H30 W38 D13



**Highlands Console Table**  
89/91-986 H27 W56 D16



**Console Table**  
89-1711 H29 W64 D15½



**Sofa Table - Stone Top**  
89/91-1714-ST H36 W70 D16½



**Sofa Table - Wood Top**  
89/91-1714-W H36 W70 D16½

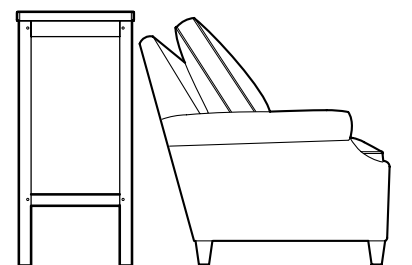



BOOKCASES & MAGAZINE RACKS



**Roycroft Little Journeys Table**  
89/91-045 H26½ W26 D15



**Music / Audio Stand**  
89-056 H41½ W25 D15

Available with two or three shelves



**Bookshelf Tower**  
89-057 H63½ W34½ D18



**Roycroft Magazine Pedestal**  
89-080 H63½ W18 D18



**Tree of Life Pedestal**  
89-504 H43½ W14 D14



**Small Bookcase (Harvey Ellis)**  
89/91-555 H30 W36 D12



**Large Bookcase (Harvey Ellis)**  
89/91-556 H30 W54 D12



**Slatted Back Bookcase**  
89/91-567 H34 W62 D14



**Slatted Back Bookcase w/6-Shelves**  
89/91-567-6 H34 W62 D14

BOOKCASES & MAGAZINE RACKS



**Gus Commemorative Bookcase**  
89-510 H53 W58 D15½



Left and Right options available

**Single Door Bookcase**  
89-633-L H55 W26 D12



**Single Bookcase with Glass Door**  
89-643 H55 W40 D12



**Magazine Rack**  
89/91-1008 H17 W18 D12



**Etagere**  
89-1046 H76 W30 D15



**Low Bookcase**  
89-1655 H31 W34 D12



**Double Bookcase with Glass Doors**  
89-645 H55 W53 D12



**Triple Bookcase with Glass Doors**  
89-647 H55 W76½ D12



**Single Door Bookcase**  
89/91-705 H58 W33 D14



**Low Bookcase**  
89-1656 H31½ W40 D12



Available without bottom doors

**Tall Bookcase w/Doors**  
89-1659-BTM H80 W34 D12



Available without bottom doors

**Tall Bookcase w/Doors**  
89-1660-BTM H80 W40 D12



**Harvey Ellis Bookcase with Inlay**  
89/91-706 H56 W56 D14



**Highlands Low Etagere**  
89/91-945 H34 W30 D15



**Highlands Etagere**  
89/91-946 H76 W30 D15



**Limbert Book Shelf**  
89/91-1701 H37 W40 D14



**Lifetime Magazine Rack**  
89-1706 H33 W16½ D16½



**Limbert Magazine Stand**  
89/91-1707 H37 W20 D14

BENCHES



**Bench**  
89-179 H30 W38 D18



**Limbert Window Bench**  
89-243 H24½ W26½ D17



**Bench**  
89/91-300 H17 W42 D18



**Highlands Bench**  
89/91-951 H18½ W50½ D21½



**Loose Cushion Limbert Bench**  
89-243-LC H24½ W26½ D17



**Gustav Stickley Fireside Stool**  
89-294 H17 W24 D13



**Storage Bench**  
89/91-1164 H22 W48 D18



**Loose Cushion Storage Bench**  
89/91-1164-LC H22 W48 D18



**Gustav Stickley Fireside Bench**  
89-294-42 H17 W42 D13



**Woven Leather Stool**  
89/91-297 H17 W19 D19



**Gus Storage Settle**  
89-1165 H36½ W48 D18



**Loose Cushion Gus Storage Settle**  
89-1165-LC H36½ W48 D18

DINING TABLES



**Round Pedestal Dining Table**

89/91-713

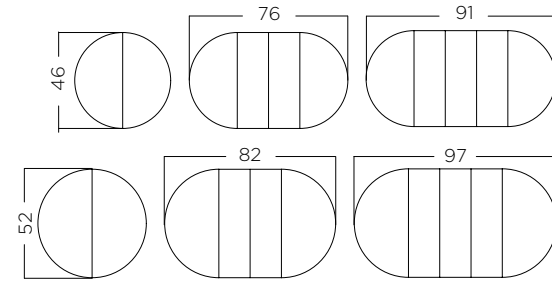

Height 30" Leaves 15"



**Highlands Pedestal Dining Table**

89/91-596

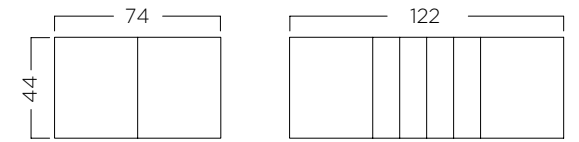

Height 30" Leaves 12"



**Harvey Ellis Dining Table**

89/91-1796

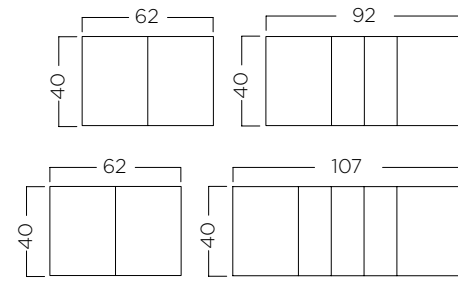

Height 30" Leaves 15"



**Highlands Trestle Table**

89/91-598

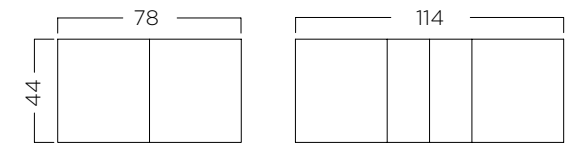

Height 30" Leaves 18"



**Harvey Ellis Dining Table**

89/91-1797

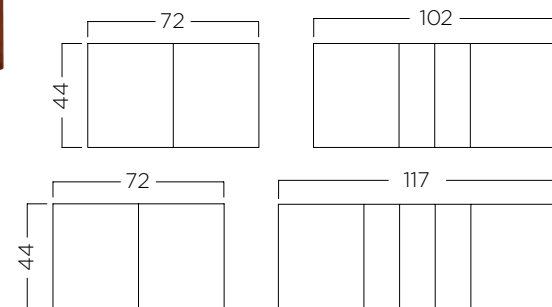

Height 30" Leaves 15"



**Highlands Round Dining Table**

89/91-594

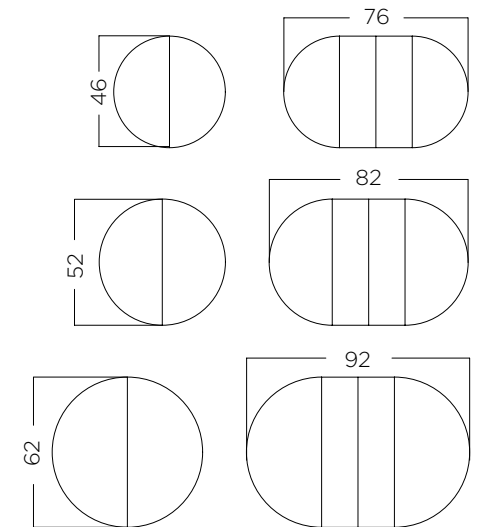

Height 30" Leaves 15"

DINING TABLES

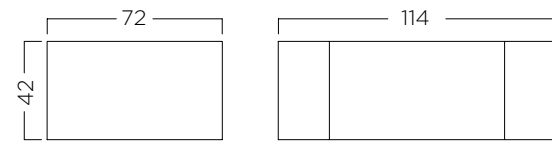

Height 30" Leaves 21"

**Mission Drawtop Dining Table**

89/91-789

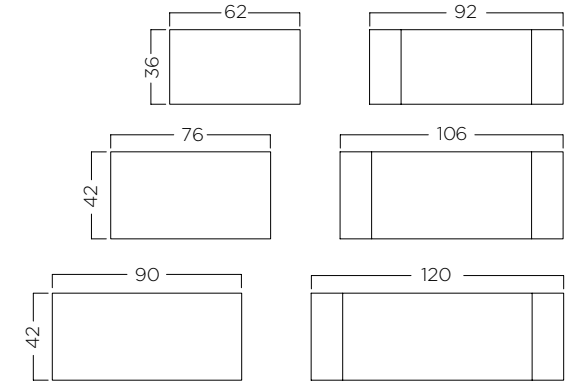

Height 30" Leaves 15"

**Keyhole Trestle Table**

89-599

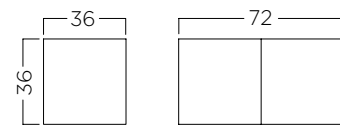

Height 31"

**Flip Top Table**

89-798

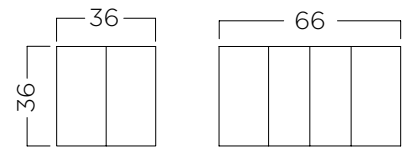

Height 30" Leaves 15"

**Breakfast Table**

89/91-584

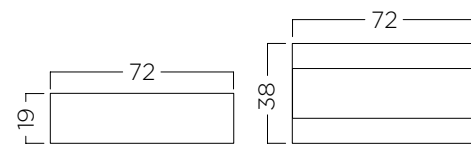

Height 30" Leaves 9½"

**Flip Top Harvest Table**

89-1735

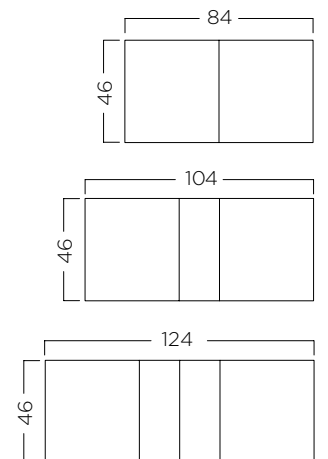

Height 30" Leaves 20"

**Grande Trestle Table**

89-1830



**V Back Arm Chair**  
89-312-A H39 W27½ D23



**V Back Side Chair**  
89-312-S H38 W19 D21½



**Cottage Arm Chair**  
89/91-323-A-W H39 W26 D25½



**Cottage Side Chair**  
89/91-323-S-W H38 W18½ D22



**Cottage Arm Chair**  
89/91-323-A H39 W26 D25½



**Cottage Side Chair**  
89/91-323-S H38 W18½ D22



**Leather Back Cottage Arm Chair**  
89/91-323-A-LB H39 W26 D25½



**Leather Back Cottage Side Chair**  
89/91-323-S-LB H38 W18½ D22



**Arm Chair**  
89/91-330-A H42 W24 D21½



**Side Chair**  
89/91-330-S H40 W17½ D21



**Harvey Ellis Arm Chair, with Inlay**  
89/91-353-A H44 W26 D24



**Harvey Ellis Side Chair, with Inlay**  
89/91-353-S H43 W18 D21



**Slatted Arm Chair**  
89-349-A H39 W26¼ D23¼



**Slatted Side Chair**  
89-349-S H39 W18¾ D21¾



**Harvey Ellis Arm Chair, no Inlay**  
89/91-354-A H44 W26 D24



**Harvey Ellis Side Chair, no Inlay**  
89/91-354-S H43 W18 D21





**Highlands Arm Chair**  
89/91-360-A H45½ W24 D25¼



**Highlands Side Chair**  
89/91-360-S H45½ W20½ D25¼



**Mackintosh Arm Chair**  
89/91-8865-A H47 W24 D25



**Mackintosh Side Chair**  
89/91-8865-S H45 W19 D24¾



**Spindle Arm Chair**  
89-386 H49 W28 D26



**Spindle Side Chair**  
89-384 H46 W19 D22



**Tall Back Upholstered Arm Chair**  
89-1833-A H44 W27½ D25



**Tall Back Upholstered Side Chair**  
89-1833-S H44 W21½ D23

SIDEBOARDS & CABINETS



**Corner Cabinet w/Art Glass**  
89-134 H78 W38 D27½



**Syracuse Sideboard**  
89-440 H40 W81 D25



**Gus Sideboard**  
89-967 H43 W60 D24



**Three Door China Top** H48 W68½ D15½  
**Three-Door Buffet** 89-1730 H34 W68½ D18



Oak version comes with Dark copper hardware.

**Sideboard**  
89/91-711 H46½ W60 D22

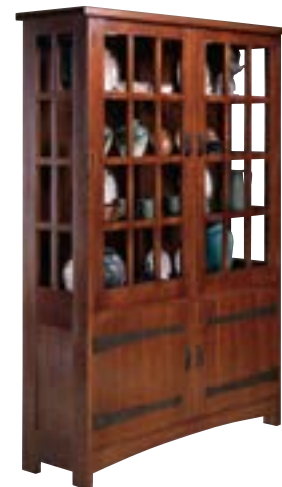

**China Cabinet**  
89-729 H77 W55 D17



**Three Door China Top** H48 W68½ D15½  
**Three-Door Buffet** 89-1730 H34 W68½ D18



**Highlands Server**  
89/91-1737 H30 W70 D21



Mirror back option available

**Display Cabinet**  
89/91-761 H78 W29 D16



**Dinner Gong**  
89-812 H36 W31 D12



**Highlands Buffet**  
89/91-1750 H40 W72 D20¼



**Harvey Ellis Sideboard**  
89/91-1791 H38 W60 D22

SIDEBOARDS & CABINETS



**Harvey Ellis Three-Door Buffet**   **Harvey Ellis China Top**  
89/91-1792   H34 W58½ D20½   89/91-1793   H48 W58½ D16½



**Harvey Ellis Four-Door Buffet**   **Harvey Ellis China Top**  
89-1794   H34 W75 D20½   89-1795   H48 W75 D16½



**Two Door Display Buffet**  
89-1907   H42 W52 D19½



Available with Three Drawers

**Three Door Display Buffet**  
89-1908   H42 W78 D19½



**Display Cabinet**  
89-1815   H78½ W38 D15

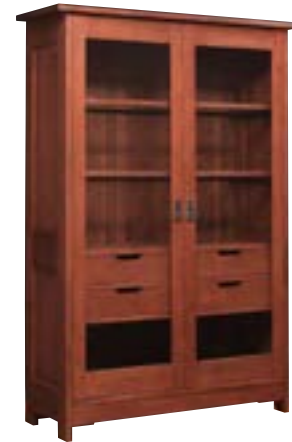

**Mission Display Cabinet**  
89/91-1818   H73½ W48½ D18



**Argyle Street Bistro Table**  
89-1799   H36 W38 D38



**Bistro Table**  
89-721   H42 Dia 30



Mirror back option available

**Highlands Display Cabinet**  
89/91-1820   H80 W36 D17¼



**Sideboard**  
89-1901   H40 W74½ D23

KITCHEN & BAR



Available with or without Bottom Door, Storage, and Wine Rack options

**Harvey Ellis Fall Front Bar**  
89/91-468   H46 W42 D15½



**Mobile Bar**  
89-1690   H47 W72 D30½

# BEDS



Options:  
 Headboard Only  
 Low Footboard  
 Platform Storage

Queen H47½ W63½ L85¾  
 King H47½ W80 L85¾

**Panel Bed**  
 89-620



Options:  
 Low Footboard  
 Mid Footboard  
 Platform Storage

Queen H59½ W64 L87  
 King H59½ W80 L87  
 Cal King H59½ W77 L91

**Harvey Ellis Bed**  
 89/91-672



Options:  
 Platform Storage

Queen H64 W68½ L91½  
 King H64 W84½ L91½  
 Cal King H64 W80½ L95½

**Prairie Bed**  
 89-684



Options:  
 Headboard Only  
 Low Footboard  
 Platform Storage

Queen H50 W63½ L85½  
 King H50 W79 L85½

**Slat Bed**  
 89-693



Options:  
 Headboard Only  
 Low Footboard  
 Mid Footboard  
 Platform Storage

Twin H49 W49½ L82  
 Full H49 W64½ L82  
 Queen H49 W70½ L87  
 King H49 W87 L87  
 Cal King H49 W84 L91

**Spindle Bed**  
 89/91-912



Options:  
 Headboard Only  
 Mid Footboard  
 Platform Storage

Queen H51 W64 L95  
 King H51 W80 L95

**Sleigh Bed**  
 91-924



Options:  
 Headboard Only  
 Low Footboard  
 Platform Storage

Queen H58 W70¾ L86½  
 King H58 W86¾ L86½  
 Cal King H58 W86¾ L90½

**Highlands Bed**  
 89/91-952



Queen H51 W64 L85½  
 King H51 W80 L85½  
 Cal King H51 W80 L89½

**Glasgow Platform Bed**  
 91-8728



Options:  
 Headboard Only  
 Platform Storage

Queen H56½ W65 L88½  
 King H56½ W81 L88½  
 Cal King H56½ W81 L92½

**Highlands Upholstered Bed**  
 89/91-953



**PLATFORM STORAGE BED SYSTEM**

Available on all Stickley beds, the platform storage system turns the space under the bed into practical and easy to use storage. The platform has over 19 cubic feet of space, with four large capacity draws and a full-width storage nook.



Options:  
 Headboard Only  
 Platform Storage

Queen H56½ W65 L88½  
 King H56½ W81 L88½  
 Cal King H56½ W81 L92½

**Highlands Pierced Slat Bed**  
 89/91-955

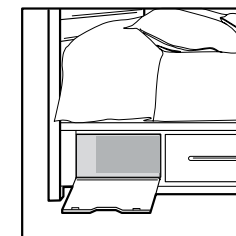

Pull-down doors at the head of the bed provide access to a velvet lined 4¾ cu. ft., through bed storage compartment for extra long items.

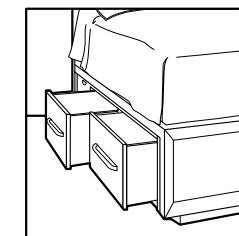

Drawers fully extend on metal gliders for easy opening. Holds up to 125 lbs. and has 3½ cu. ft. of storage. The drawers are sealed, keeping dust out.

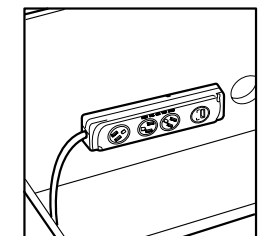

Platform storage beds come complete with power strip and cable management to neatly arrange lamps, radio and charger cables.



## DRESSERS & NIGHTSTANDS



Oak dressers & night stands have dark copper drawer pulls.



Cherry dressers with curly maple drawer fronts have walnut pulls on a walnut inlay with copper ring.



Cherry dressers with solid cherry drawer fronts have cherry pulls.



**Triple Dresser**

89-625

H35½ W66 D20



**Chest**

89-627

H54½ W40 D20



**Lingerie Chest**

89-628

H53 W22 D16



**Master Dresser**

89-637

H46½ W66 D20



**One Drawer Night Stand**

89-611

H27½ W22 D16

DRESSERS & NIGHTSTANDS



**Three Drawer Night Stand**  
89-613 H27½ W22 D16



**Three Drawer Chest**  
89-614 H31 W30 D18



**Harvey Ellis Lingerie Chest**  
89-917 H56 W26 D17½



**Harvey Ellis Tall Chest**  
89-923 H60½ W43 D20



**Harvey Ellis Single Dresser**  
89-901 H35½ W48 D20



**Harvey Ellis Bachelor's Chest**  
89-902 H34½ W38 D20



**Harvey Ellis High Double Dresser**  
89-926 H46½ W60 D20



**Harvey Ellis Master Dresser**  
89-927 H46 W71 D20



**Harvey Ellis Seven Drawer Dresser**  
89-907 H36½ W71 D20



**Harvey Ellis Nine Drawer Chest**  
89-913 H55½ W37½ D20



**Harvey Ellis Door Night Stand**  
89-908 H32½ W32½ D17



**Open Night Stand**  
89-909 H29½ W26 D17

DRESSERS & NIGHTSTANDS



**Three Drawer Night Stand**  
89-910 H29½ W26 D17



**Harvey Ellis Single Dresser**  
91-901 H33 W48 D20



**Harvey Ellis Tall Chest**  
91-923 H57½ W43 D20



**Harvey Ellis High Double Dresser**  
91-926 H44 W60 D20



**Harvey Ellis Bachelor's Chest**  
91-902 H32 W38 D20



**Harvey Ellis Seven Drawer Dresser**  
91-907 H34 W71 D20



**Harvey Ellis Master Dresser**  
91-927 H44 W71 D20



**Harvey Ellis Door Night Stand**  
91-908 H30 W32½ D17



**Harvey Ellis Nine Drawer Chest**  
91-913 H53 W37½ D20



**Harvey Ellis Lingerie Chest**  
91-917 H54 W26 D17½



**Open Night Stand**  
91-909 H27 W26 D17



**Three Drawer Night Stand**  
91-910 H27 W26 D17



DRESSERS & NIGHTSTANDS



**Harvey Ellis Single Dresser**  
91-901-CH H33 W48 D20



**Harvey Ellis Bachelor's Chest**  
91-902-CH H32 W38 D20



**Harvey Ellis High Double Dresser**  
91-926-CH H44 W60 D20



**Harvey Ellis Master Dresser**  
91-927-CH H44 W71 D20



**Harvey Ellis Seven Drawer Dresser**  
91-907-CH H34 W71 D20



**Harvey Ellis Nine Drawer Chest**  
91-913-CH H53 W37½ D20



**Harvey Ellis Door Night Stand**  
91-908-CH H30 W32½ D17



**Open Night Stand**  
91-909-CH H27 W26 D17



**Harvey Ellis Lingerie Chest**  
91-917-CH H54 W26 D17½



**Harvey Ellis Tall Chest**  
91-923-CH H57½ W43 D20



**Three Drawer Night Stand**  
91-910-CH H27 W26 D17



**Jewelry Chest**  
89-1145 H42 W19½ D16

DRESSERS & NIGHTSTANDS



**Highlands Master Chest**  
89/91-954 H52 W54 D20¼



**Highlands Master Dresser**  
89/91-956 H43¾ W72½ D20¼



Left and Right Hinged options available

**Somno Cabinet**  
89-605-L/R H30 W18 D16



**Blanket Chest**  
89-097 H25 W42 D22½



**Highlands Low Armoire**  
89/91-957 H52 W70½ D22½



**Highlands 3-Drawer Night Stand**  
89/91-958 H30 W34 D17¾



**Two Drawer Tall Night Stand**  
89/91-641 H29 W20 D17½



Left and Right Hinged options available

**Cabinet Hinged**  
89-1026-L/R H29 W20 D17



Left and Right Hinged options available

**Highlands Door Night Stand**  
89/91-959-L/R H28 W22 D17¾



**Highlands 2-Drawer Chest**  
89/91-988 H19 W50 D18



Left and Right Facing options available

**Glasgow Night Stand w/Lattice**  
91-8725-L/R H46 W35¾ D21¼



**Glasgow Night Stand**  
91-8726 H28¼ W28¾ D21¼

# HOME OFFICE



## OFFICE CHAIRS



**Swivel Tilt Desk Chair**  
89/91-323-A-SW H Adj. W26 D27



**Leather Back Swivel Tilt Desk Chair**  
89/91-323-A-SW-LB H Adj. W26 D27



**Armless Swivel Chair**  
89-325-S-SW H Adj. W27 D27



**Armless Swivel Chair Leather back**  
89-325-S-SW-LB H Adj. W27 D27

DESKS & ORGANIZERS



**Westcott Street Library Table**  
89-409 H31 W60 D36



**Harvey Ellis Organizer**  
89/91-466 H46 W27 D15½



**Ellis Fall Front Bookcase**  
89/91-477-G H56 W56 D15



**Library Table with Keyboard Pullout**  
89-660 H30 W66 D32



Available with or without Bottom Door, Storage, and Wine Rack options

**Harvey Ellis Fall Front Desk**  
89/91-467 H46 W42 D15½



**Harvey Ellis Fall Front Bookcase**  
89-477 H56 W56 D15



**Lee Drop Front Desk**  
89-661 H44½ W42½ D20½



**Highlands Desk**  
89/91-948 H30 W60 D30



**Harvey Ellis Desk**  
89-472 H30½ W42 D24



**Harvey Ellis Deck (shown with desk)**  
89-473 H10 W31 D8



**Writing Desk**  
89-730 H30 W43 D26



**Deck (shown with desk)**  
89-731 H11 W41 D10

DESKS & ORGANIZERS



**Highlands Writing Desk**  
89/91-949 H30 W62 D30



**Spindle Library Desk**  
89/91-1283 H29½ W50 D24  
Available with Left and Right Keyboard  
Drawer options



**Kneehole Desk**  
89-2254 H30 W54 D28



**Two Drawer File Unit**  
89/91-2521 H31½ W22½ D28



**Four Drawer File Unit**  
89/91-2522 H57 W22½ D28



**Executive Desk**  
89/91-2266 H30 W66 D33



**Executive Desk**  
89/91-2272 H30 W72 D36



**Computer Work Table**  
89/91-2586 H30 W60 D30



**Mobile Printer/File Stand**  
89/91-2589 H22 W22½ D27½



**Hi-Lo Standing Desk**  
89/91-1285 H Adj. W62 D28



**Gus Library Table**  
89-2653 H30 W48 D30



**Fall Front Desk**  
89-1729 H44½ W36½ D15



## HOME OFFICE WORK STATION

<b>File Unit</b>	89-2530	H30 W30 D22
<b>Door Unit</b>	89-2531	H30 W30 D22
<b>Keyboard Drawer</b>	89-2532	H5½ W30 D22
<b>Corner Keyboard Drawer</b>	89-2534	H5½ W43½ D43½
<b>Inside Support</b>	89-2535	H29 W1 D20¼
<b>Outside End Panel</b>	89-2536	H29 W1 D20¼
<b>30" Pencil Drawer Unit</b>	89-2537	H5½ W30 D22
<b>Upper Bookcase</b>	89-2540	H44½ W30 D13¼
<b>Upper Bookcase with Doors</b>	89-2541	H44½ W30 D13¼
<b>Upper Corner Unit</b>	89-2550	H44½ W43½ D43½

## MIRRORS



**Mirror**  
89-018

H23½ W29½



Available without hooks

**Three Glass Mirror with Hooks**  
89-068

H32 W54½



**Harvey Ellis 3-Glass Mirror**  
89-562

H18¾ W33 D1



**Secret Looking Glass (Harvey Ellis)**  
89-563

H18 W13¾ D2¼



**Harvey Ellis Mirror**  
89/91-846

H42 W23½ D2



**Cheval Mirror**  
89/91-918

H62 W26 D16



**Highlands Mirror**  
89/91-950

H35¼ W48 D2½



**Harvey Ellis Mirror**  
89/91-970

H34 W48 D2½



**Harvey Ellis Mirror**  
89/91-971

H34 W48 D2½

CLOCKS & ACCESSORIES



**Bracket Clock**  
89-065 H6 W4½ D1½



**Wedding Mantel Clock**  
89-081 H23½ W16 D6½



**Small Mantel Clock**  
89-083 H13¾ W8½ D4¼



**Mantel Clock**  
89-098 H15 W12½ D5



**Desk Box**  
89/91-003 H3¾ W10 D7



**Harvey Ellis Jewelry Box**  
89/91-073 H7½ W18 D11



**Bracket Clock**  
89/91-084 H8½ W8¼ D2¾



**Asheville Clock**  
89-107 H86½ W39 D13½



**Asheville Clock (Strap Hinge)**  
89-107-SH H86½ W39 D13½



**Bread Board**  
89-010 H¾ W14 D8



**Cheese Board**  
89/91-029 H¾ W11 D7



**Dinner Gong**  
89-812 H36 W31 D12



**Mantel Clock**  
89-085 H22 W16 D8



**Double Costumer**  
89-088 H72 W24 D20½



**Single Costumer**  
89/91-089 H72 W24 D24



**Gustav Stickley Collector Chest**  
89-095 H16 W32 D17

# LAMPS



## LAMPS



Available with Art Glass Shade or Mica Shade

### Small Lamp

89-030-1 H18 W9 D9



Available with Art Glass Shade or Mica Shade

### Small Corbel Base Lamp

89/91-031-2 H21 W12 D12



### Corbel Base Table Lamp

89/91-032-3 H27 W20 D20



### Corbel Base Table Lamp

89/91-032-L6 H27 W18 D18



### Corbel Base Table Lamp

89/91-032-M3 H27 W18 D18



### Square Base Table Lamp

89/91-033-4 H29 W12 D12



### Square Base Table Lamp

89/91-033-L4 H29 W14 D14



### Square Base Table Lamp

89/91-033-M2 H29 W12 D12



### Torchiere Floor Lamp

89-034-10 H70 Dia 19



LAMPS



**Square Base Floor Lamp**  
89/91-036-7 H58½ W19 D19



**Square Base Floor Lamp**  
89/91-036-L7 H58½ W18 D18



**Square Base Floor Lamp**  
89/91-036-M4 H58½ W19 D19



**Cross Base Table Lamp**  
89-039-M3 H29 W18 D18



**Table Lamp**  
89/91-041-11 H29 W18 D18



**Ellis Table Lamp**  
89/91-042-11 H29 W18 D18



**Octagonal Base Floor Lamp**  
89-037-8 H58½ W21 D21



**Octagonal Base Floor Lamp**  
89/91-037-M4 H58½ W19 D19



**Corbel Base Floor Lamp**  
89/91-038-9 H58½ W19 D19



**Table Lamp**  
89/91-043-4 H24½ W12 D12



**Table Lamp**  
89/91-043-L4 H24½ W14 D14

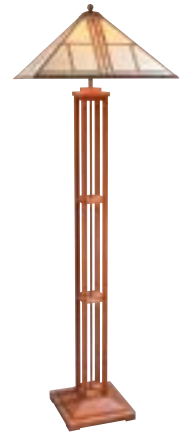

**Floor Lamp**  
89/91-058-7 H64½ W19 D19



**Corbel Base Floor Lamp**  
89-038-M4 H58½ W19 D19



**Cross Base Table Lamp**  
89-039-5 H29 W20½ D20½



**Cross Base Table Lamp**  
89-039-L6 H29 W18 D18



**Floor Lamp**  
89/91-058-L7 H64½ W18 D18



**Limbert Open Pedestal**  
89-1702 H46 W12½ D12½



**Gus Newel Post Lamp**  
89-1703 H60 W13 D13

# PASADENA BUNGALOW



# LIVING ROOMS



## PASADENA BUNGALOW



**Gamble House Bookcase**  
AN-7315-299 H54½ W46 D15



**Oak Knoll Display Cabinet**  
AN-7318-299 H82 W42 D17



**78" Pasadena Gathering Island**  
AN-7340-299 H36 W78 D20¾



**90" Pasadena Gathering Island**  
AN-7340-90-299 H36 W90 D20¾



**Pasadena Counter Stool**  
AN-7342-C-299 H26 W17 D17



**60" Hillcrest Entertainment Console**  
AN-7343-60-299 H30 W60 D16½



**48" Hillcrest Entertainment Console**  
AN-7343-48-299 H30 W48 D16½



**Blacker House Shoe Bench**  
AN-7347-299 H36 W52 D24



**Tsuba Bustle Back Recliner**  
AN-7381-RL-299 H40 W35¾ D40



**San Gabriel Cocktail Table**  
AN-7383-299 H18 W56 D23



**Gamble House Buffet**  
AN-7350-299 H34 W65 D18½



**Gamble House China Top**  
AN-7351-299 H49½ W67½ D15½

**Gamble House Buffet**  
AN-7350-299 H34 W65 D18½



**Gamble House Console**  
AN-7384-299 H32 W54 D15



**San Gabriel End Table**  
AN-7388-299 H26 W23 D18½



**East Colorado Rocker**  
AN-7367-299 H42 W23 D25



**Arroyo Storage Tabouret Table**  
AN-7369-299 H18 W17½ D17½



**San Gabriel Sofa Table**  
AN-7389-299 H30 W52 D16



**Tsuba End Table**  
AN-7387-299 H26 W24¾ D30



**Oak Knoll Cocktail Table**  
AN-7385-299 H18 W56 D30¼



**Oak Knoll End Table**  
AN-7386-299 H26 W24¼ D28



**Oak Knoll Chair**  
AN-7398-CH-299 W33 D40 H33½



**Oak Knoll Ottoman**  
AN-7398-OT-299 W25¼ D18¼ H16½



**Oak Knoll Sofa**  
AN-7398-90-299 W90 D40 H33½



# DINING ROOMS



## PASADENA BUNGALOW



**Tsuba Small Dining Table**  
AN-7330-46-299 H30 W46 D46



**San Gabriel Breakfast Table**  
AN-7331-299 H30 W36 D36



**Blacker House Arm Chair**  
AN-7353-A-299 H38 W23 D24



**Blacker House Side Chair**  
AN-7353-S-299 H38 W22 D23½



**East Colorado Arm Chair**  
AN-7355-A-299 H42 W23 D25



**East Colorado Side Chair**  
AN-7355-S-299 H42 W20 D24

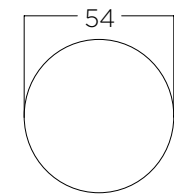
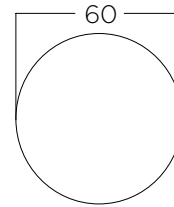

**Thorsen Round Dining Table**  
AN-7357-2LVS-299 H30 Dia 60

**Thorsen Round Dining Table**  
AN-7359-2LVS-299 H30 Dia 54

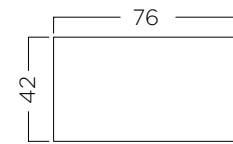

**San Marino Trestle Table**  
AN-7361-76-2LVS-299 H30 W42 L76



**Oak Knoll Sideboard**  
AN-7365-W-299 H36 W74 $\frac{3}{4}$  D20 $\frac{1}{2}$



**Oak Knoll Sideboard**  
AN-7365-GT-299 H36 W72 D20 $\frac{1}{4}$



# BEDROOMS



## PASADENA BUNGALOW



**Fullerton Night Stand**

AN-7301-299 H29 W26 D17½



**Inglewood Night Stand**

AN-7302-299 H30 W31 D17½



**Burbank Single Dresser**

AN-7303-299 H34½ W48 D20



**Huntington Triple Dresser**

AN-7304-299 H41 W68 D20



**Brookside Tall Chest**

AN-7310-299 H58 W40 D20½





**Oak Knoll Open Night Stand**  
AN-7323-299 H25 W30 D18



**Oak Knoll Tall Chest**  
AN-7327-299 H60 W46½ D20



**Arcadia Vertical Mirror**  
AN-7308-299 H44 W26 D1½



**Covina Landscape Mirror**  
AN-7309-299 H37 W51 D1½



**Oak Knoll Single Dresser**  
AN-7328-299 H37½ W57 D20



**Oak Knoll Master Dresser**  
AN-7329-299 H38 W74 D20



**Pasadena Sleigh Bed**  
AN-7317

Options:  
Platform Storage  
Mid Footboard

Queen	H54	W65	L92½
King	H54	W81	L92½
Cal King	H54	W81	L96½



**Spindle Platform Bed**  
AN-7326

Queen	H49½	W69	L95
King	H49½	W85	L95
Cal King	H49½	W85	L99



**Tsuba Mirror**  
AN-7320-299 H36 W46 D1¼



**Sumner Writing Desk**  
AN-7378-299 H30 W52 D26½

# STICKLEY STARTERS



**Bed Extension Kit (Converts Twin to Full size bed)**  
AN-1958-032 H17½ W79½ L15

## STICKLEY STARTERS



**Twin Bed**  
AN-1970-T H41 W46 L84

**Assembly Kit (Requires two beds)**  
AN-1970-KIT-032



**Trundle Bed Unit**  
AN-1984-032 H11 W41 L75½

**Bed Storage Unit**  
AN-1985-032 H12 W41 L76



**Twin Willow Bed**  
AN-1986-T-032 H55 W43½ L81



**Single Drawer Night Stand**

AN-1971-032 H25 W22 D17



**Three Drawer Night Stand**

AN-1987-032 H25 W22 D17



**Dresser Hutch**

AN-1980-032 H48 W45 D13½



**Dresser**

AN-1979-032 H30 W45 D19



**Bachelor Chest**

AN-1976-032 H30 W30 D19



**Dressing Chest**

AN-1927-032 H40¼ W35½ D18½



**Student Bookcase**

AN-1956-032 H53 W28 D12½



**Child's Rocker**

AN-1330-R-032 H26½ W18¼ D21¼



**Dresser**

AN-1972-032 H30 W46½ D19



**High Chest**

AN-1973-032 H48½ W38 D19



**Child's Side Chair**

AN-342-S-032 H24 W14 D14½



**Child's Table**

AN-1640-032 H19 W30 D21



STICKLEY STARTERS



**Mirror**  
AN-1975-032 H45 W28 D1½



**Student Desk Chair**  
AN-1983-032 H35 W18 D19



**Student Hutch**  
AN-1955-032 H23 W45 D12½



**Computer Desk Hutch**  
AN-1982-032 H48 W51½ D13½



Matching Student Desk Hutch available.

**Student Desk**  
AN-1988-032 H30 W45 D19



**Computer Desk**  
AN-1981-032 H30 W50 D24

STANDARD OAK MISSION FINISHES



**35 - Fayetteville**  
A light amber brown, low sheen finish. Named for the village outside Syracuse, New York where the original L. & J. G. Stickley factory still stands.



**54 - Aurora**  
A honey brown, low sheen finish. Named for East Aurora, New York, home of Roycroft furniture.



**32 - Onondaga**  
A warm, reddish brown finish. Named for Onondaga County - the home of Stickley since 1900.

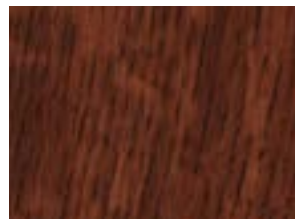

**77 - Manlius**  
A rich dark brown medium sheen finish. Named for the village outside of Syracuse New York, location of the current L. & J. G. Stickley factory.



**31 - Centennial**  
A deep rich patina and medium sheen. Originally developed for the Grove Park Inn Hall Clock.

MODERN OAK MISSION FINISHES



**501 - Sand**  
Make every day feel as relaxed as a long weekend with this spacious and airy color that evokes the rich warmth of a sun-drenched beach. (low sheen)



**502 - Fieldstone**  
Bring a handsomely sleek and sophisticated feeling to your spaces with this deeply flecked modern finish inspired by the warm hues of weather-worn stone and driftwood. (low sheen)



**503 - Lodge**  
Take tradition uptown with the versatility of this rich, deep chocolaty brown that exudes warmth and comfort. (low sheen)



**505 - Onyx**  
Make a striking statement in deep black with subtle contrasting grain that shimmers as the lights plays across it. (low sheen)

Modern Oak Finishes available with light distressing

STANDARD CHERRY MISSION FINISHES



**718 - Morris Plains**  
The natural color and aging of cherry is celebrated with this low sheen finish. Named for the location of Gustav Stickley's summer home.



**713 - Central Valley**  
A warm low sheen finish that subtly enhances the natural red brown color of cherry. Named for the summer home of the Audi Family.



**299 - Pasadena**  
Developed originally for the Pasadena Bungalow collection, this warm medium sheen finish accentuates the natural deep red found in cherry.

\*Pasadena Bungalow Collection only available in 299



**11 - Madison**  
A soft brown with a low sheen, antique patina.



**067 - Vesper**  
Dark cherry brown finish and deep sheen produce a rich sophisticated look.



**91N - Bristol**  
A honey brown stain with no distressing that is hand rubbed to a medium sheen.



**92N - Windsor**  
Cherry brown stain rubbed to a medium sheen with no distressing.



**93N - Oxford**  
Deep walnut brown stain with a medium sheen, no distressing.

Bristol, Windsor, and Oxford available with light distressing

NOTE: The finishes pictured are for general reference only. Please visit your Authorized Stickley Dealer to experience first-hand the beauty of these finishes.

## TILE OPTIONS



Twilight Gray



Ocean Blue

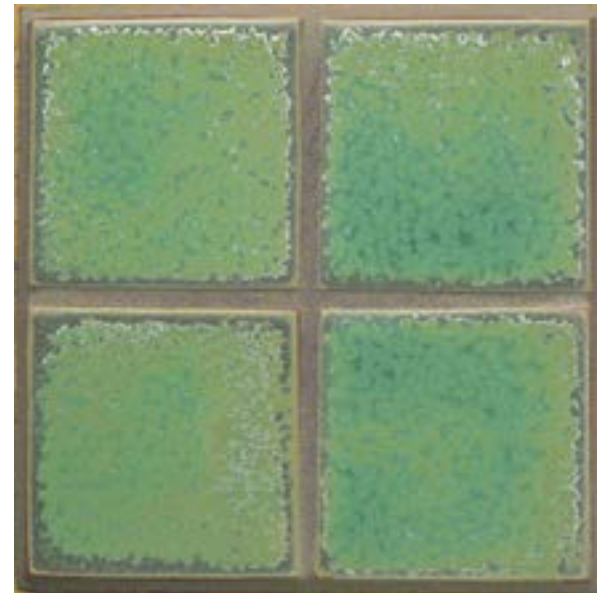

Meadow Green



Canyon Copper

Our handcrafted tiles will slightly vary in color, surface effect, and finish. No two are exactly alike. Please visit your nearest showroom for more detail than these general reference photos allow.

## CARE

Since 1900, Sticklely has been making history by creating furniture that is a work of art. To preserve the original beauty of the furniture which will undoubtedly be enhanced with age, Sticklely furniture should be cherished and cared for accordingly.

- Avoid exposure to strong sunlight which may cause discoloration.
- When projecting tops of tables and desks with glass, do not use felt dots, plastic dots, or cork under the glass.
- Lift objects, do not drag them.
- Avoid exposure to extreme heat or cold by using table pads. Trivets and placements are useful, but will not prevent blushing if utensils are extremely hot.
- Do not use nail polish remover, hair spray, or perfume (most of which contain alcohol) near the furniture.
- Be cautious about placing rubber or plastic products on the furniture since a chemical reaction may cause deterioration in the finish.
- Store table leaves flat in an environment free from extreme temperatures or humidity.
- Do not place heavy objects or table pads on freshly polished surfaces.

## DESIGN

Sticklely reserves the right to change, modify, discontinue, or improve any product designs, finishes, or specifications at its discretion, and without prior notice.

## WARRANTY

Sticklely believes so strongly in the integrity of our workmanship that we offer you the Sticklely Lifetime Promise. We want you to be truly pleased with your Sticklely furniture as it becomes an important part of your family for generations to come.

We offer a Manufacturer's Limited Lifetime Warranty against defects on all case goods except dining and office chairs. Should the furniture fail structurally at any time during the lifetime of the original owner, because of workmanship or material, we will repair or replace at our discretion.

Sticklely offers a Five Year Limited Warranty against defects on the following: dining chairs, office chairs, finishes, and mechanical devices (clock movements, recliner movements, etc.). Should these items fail within five years of purchase due to manufacturing defects, we will repair or replace it at our discretion.

This warranty does not apply to fabric or leather supplied by Sticklely or the customer. Warranty does not apply to customer damage, alteration, or accident. Seasonal wood movement on solid wood products is normal and is not considered a warranty issue. For a copy of the Sticklely Warranty in its entirety, please ask your Sticklely retailer or visit us at: [Stickley.com](http://Stickley.com).

With proper care, and the Sticklely Lifetime Promise, you can be assured that your Sticklely furniture is destined to become a cherished family heirloom.

## THE CHARACTER OF OAK

Sticklely uses solid quartersawn white oak for its Mission Collection in keeping with the tradition of the Sticklely brothers in the early 1900s. Quartersawn white oak was favored then and now because its dimensional stability: it is less likely to crack, check or warp due to the method of cutting. This method also results in ray flake. Just as there are variations in ray flake patterns on antique pieces of Sticklely, there will be ray flake variations on today's Sticklely pieces.

## THE CHARACTER OF CHERRY

As cherry ages, it mellows and deepens in color. Many owners of vintage Sticklely furniture will attest to this rich patina that develops over time. This natural phenomenon makes each piece of cherry furniture a unique work of art. The degree of color change will depend on the finish selected and the furniture's exposure to light. Please note that newer pieces will vary slightly in color from older pieces due to this characteristic, even if they are in the same finish.

Cherry wood can contain small sap pockets or twig starts that may appear to be blemishes, but are completely natural and to be expected in any piece of solid cherry furniture. Another characteristic of cherry is its broad color spectrum - ranging from deep red to nearly white, with every color tone in between.

At Sticklely, craftspeople blend the shades and grain of cherry to create a balance on each piece, but there will be variations visible. You are buying a product of nature, so be sure to enjoy the organic character of each piece.

## CONSERVATION & SUSTAINABILITY

The ultimate in ecological sustainability is that Sticklely is Green from beginning to end and is committed to crafting furniture that gets passed down from generation to generation.

The wood that is used to craft Sticklely furniture comes from sustainable, family-owned forests that have partnered with Sticklely for decades. Sticklely oak comes from Western Kentucky while wild black cherry comes from forests in Pennsylvania and New York; both wood species today are a renewable resource.

Once the lumber arrives in the factory, the sustainable practices continue. Sticklely's 420,000 square foot Manlius, New York factory is heated entirely by sawdust during chilly upstate New York winters, and Sticklely employees use oak and cherry scraps to heat their homes. The remainder of the wood waste goes to a company that makes heating pellets.

Sticklely has re-fitted the factory, offices and showrooms with energy efficient lighting, thus cutting lighting energy use roughly in half. Sticklely has an extensive Blue Bin program for recycling paper, cardboard, and plastic bottles. At Sticklely very little, if anything, is wasted.

Efficiency and intelligent conservation are also central to Sticklely Fine Upholstery. Down and feather fillings are all natural and environmentally friendly. The urethane foams in Sticklely sofas and chairs contain the maximum percentage of soybean derived polyols, reducing petroleum inputs. Urethane foams are PDBE free and hardwood frames are formaldehyde free.

And perhaps the greenest thing of all is that Sticklely furniture is of such a high quality that it lasts for generations - never taking up space in a landfill.

Over 93 percent of Sticklely's products are still made by Sticklely craftspeople in upstate New York and North Carolina workshops. Sticklely complies with strict federal, state, and local environmental regulations and is a proud member of the Sustainable Furnishings Council.



# ROOM INDEX



## Pages 8-9

- 89-1184 Bridge
- 89-1186 Etagerie
- 89-1188 Highlands Entertainment Console
- 89-1708 Highlands 78" Gathering Island
- 89-305-C Counter Stool
- 89-9800-85-L Highlands LF Sofa
- 89-9800-94-R Highlands RF Corner Sofa
- 89-9800-CH Highlands Chair
- 89-9800-OT Highlands Ottoman
- 89-981 Highlands Square Cocktail Table
- 89-984 Highlands End Table
- RU-1400-8X10 Monterey Grove Rug



## Pages 10-11

- 89-9800-88 Highlands Sofa
- 89-9800-CH Highlands Chair
- 89-9800-COT Highlands Cocktail Ottoman
- 89-986 Highlands Console Table
- 89-1189 Highlands Entertainment Console



## Pages 12-13

- 89-949 Highlands Writing Desk
- 89-8865-A Mackintosh Arm Chair
- RU-5000-6X9 Thistle Meadows



## Pages 26-27

- 89-369 Spindle Morris Chair
- 89-395 Footstool
- 89-466 Harvey Ellis Organizer



## Pages 28-29

- 89-1005 Gus Tea Table
- 89-1703 Gus Newel Post Lamp
- 89-1725 Eastwood Ottoman
- 89-2638 Eastwood Chair



## Pages 30-31

- 96-9125-95 Fargo Sofa
- 96-9109-CH-TB Essex Tight Back Chair
- 89-981 Highlands Square Cocktail Table
- 89-983 Highlands Oval End Table
- 89-984 Highlands End Table



## Pages 14-15

- 89-9236-82-PR Orchard Street Sofa
- 89-406-RL-PR Bustle Back Bow Arm Morris Recliner
- 89-1324-R-LC Loose Cushion Gus Rocker
- 89-756 Three Drawer Cocktail Table
- 89-746 End Table
- 89-470 Harvey Ellis Round Lamp Table
- 89-594-52 Highlands Round Dining Table
- 89-8865-A Mackintosh Arm Chair



## Page 16-17

- 89-050 Roycroft Tabouret
- 89-1005 Gus Tea Table
- 89-1324-R Gus Rocker
- 89-208-LC Settle
- 89-743 Harvey Ellis Storage Cocktail Table



## Pages 18-19

- 89-1184 Bridge
- 89-1185 TV Console
- 89-1186 Etagerie
- 89-1324-R Gus Rocker
- 89-1712-90-ST Gathering Island
- 89-305-C Counter Stool
- 89-581 Tile Top Cocktail Table
- 96-9088-102-L Chicago Right Facing Corner Section
- 96-9088-91-L Chicago Left Facing Section



## Pages 32-33

- 89-330-A Arm Chair
- 89-330-S Side Chair
- 89-713-46-2LVS Round Pedestal Dining Table



## Pages 34-35

- 89-599 Keyhole Trestle Table
- 89-384 Spindle Side Chair
- 89-386 Spindle Arm Chair
- 89-1908 Three Door Display Cabinet



## Pages 36-37

- 89-1794 Harvey Ellis Four Door Buffet
- 89-1795 Harvey Ellis China Top
- 89-1797-2LVS Harvey Ellis Dining Table with Inlay
- 89-353-A Harvey Ellis Arm Chair with Inlay
- 89-353-S Harvey Ellis Side Chair with Inlay



## Pages 20-21

- 96-9082-86 Park Ridge Sofa
- CL-8082-COT Park Ridge Cocktail Ottoman
- CL-8082-CH Park Ridge Chair
- 89-1712 Gathering Island
- 89-328-C Counter Stool
- 89-536 Round Lamp Table

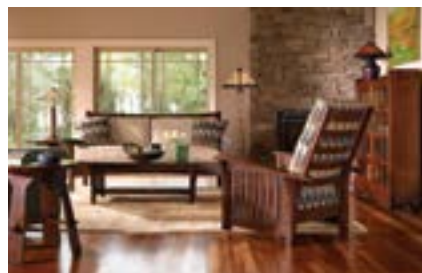

## Pages 22-23

- 9-1263 Slat Back Settle
- 89-033-4 Square Base Table Lamp
- 89-058-7 Floor Lamp
- 89-1005 Gus Tea Table
- 89-509 Drop Leaf Table



## Pages 24-25

- 89-9234-82 Fayetteville Sofa
- 89-2638 Eastwood Chair
- 89-1725 Eastwood Ottoman
- 89-837-R Chapel Street Rocker
- 89-510 Gus Commemorative Bookcase
- 89-578 Butterfly Top Cocktail Table
- 89-663 Round Table
- 89-515 Octagonal Table
- 89-713-46-2LVS Round Pedestal Table
- 89-323-A Cottage Arm Chair



## Pages 38-39

- 91-1820 Highlands Display Cabinet
- 91-598-2LVS Highlands Trestle Table
- 91-8865-A Mackintosh Arm Chair
- 91-8865-S Mackintosh Side Chair



## Pages 40-41

- 91-8865-A Mackintosh Arm Chair
- 91-8865-S Mackintosh Side Chair
- 91-1737 Highlands Server
- 91-596-2LVS Highlands Pedestal Dining Table



## Pages 42-43

- 89-1830-2LVS Grande Trestle Table
- 89-1833 Tall Back Upholstered Arm & Side Chairs
- 89-440 Syracuse Sideboard
- 96-9062-CH Park City Wing Chair
- 89-664 Round End Table

## ROOM INDEX



### Pages 44-45

- 91-594-52-2LVS Highlands Round Dining Table
- 2216-A Upholstered Arm Chair
- 91-1737 Highlands Server

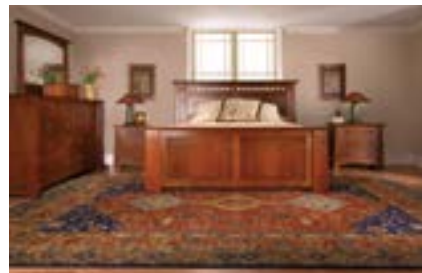

### Pages 46-47

- 89-952-K Highlands Bed King
- 89-959-L Highlands Door Night Stand
- 89-084 Bracket Clock
- 89-954 Highlands Master Chest
- 89-958 Highlands 3-Drawer Night Stand
- RU-4000-10x14 Anatolia Rust



### Pages 48-49

- 9-952-K-PLS Highlands Bed
- 89-958 Highlands 3-Drawer Night Stand
- 89-959-L Highlands Door Night Stand
- 89-957 Highlands Low Armoire



### Pages 50-51

- 89-953-K Highlands Bed
- 8538-W-ASH Uptown 3-Drawer Night Stand
- 8540-W-ASH Uptown 1-Drawer Night Stand
- 8536-W-ASH Uptown Master Dresser



### Pages 52-53

- 89-684-K Prairie Bed King
- 89-837-R Chapel Street Rocker
- 89-901 Harvey Ellis Single Dresser
- 89-039-5 Cross Base Table Lamp



### Pages 54-55

- 89-326 Harvey Ellis Cube Chair
- 89-672-K-MFB Harvey Ellis King Bed
- 89-907 Harvey Ellis Seven-Drawer Dresser
- 89-909 Open Night Stand
- 89-910 Three Drawer Night Stand
- 89-970 Harvey Ellis Mirror
- RU-1350-9x12 Donegal Rug



### Pages 56-57

- 89-684-Q Prairie Bed
- 89-637 Master Dresser
- 89-614 Three Drawer Chest

## Index

89/91-003	Desk Box .....	125	89-240	Limbert Pedestal .....	80
89-010	Bread Board .....	125	89-243	Limbert Window Bench .....	86
89-018	Mirror .....	123	89-286	Spindle Settee .....	58
89/91-028	Grand Poppy Table .....	77	89-294	Gustav Stickley Fireside Stool & Bench .....	86
89/91-029	Cheese Board .....	125	89/91-297	Woven Leather Stool .....	86
89-030	Small Lamp .....	127	89/91-300	Bench .....	87
89/91-031	Small Corbel Base Lamp .....	127	89-302	Footstool .....	63
89/91-032	Corbel Base Table Lamp .....	127	89/91-305	Bar Stool .....	73
89/91-033	Square Base Table Lamp .....	127	89-312	V Back Arm & Side Chair .....	92
89-034	Torchiere Floor Lamp .....	127	89/91-321	Spindle Bar Stool .....	73
89/91-036	Square Base Floor Lamp .....	128	89/91-322	Slat Back Bar Stool .....	73
89-037	Octagonal Base Floor Lamp .....	128	89/91-323	Cottage Arm & Side Chair .....	92
89/91-038	Corbel Base Floor Lamp .....	128	89/91-323-SW	Swivel Tilt Desk Chair .....	117, 122
89-039	Cross Base Table Lamp .....	128	89-325-SW	Armless Swivel Chair .....	117
89/91-041-11	Table Lamp .....	129	89-326	Harvey Ellis Cube Chair .....	63
89/91-042-11	Ellis Table Lamp .....	129	89-327	Harvey Ellis Shoe Foot Rocker .....	65
89/91-043	Table Lamp .....	129	89/91-328	Swivel Bar Stool .....	73
89/91-045	Roycroft Little Journeys Table .....	83	89/91-330	Arm & Side Chair .....	94
89-048	Tile Top Stand .....	79	89/91-334	Limbert Tabouret Table .....	80
89/91-049	Roycroft Tabouret Table .....	80	89-349	Slatted Arm & Side Chair .....	94
89/91-050	Roycroft Tabouret .....	80	89/91-353/4	Harvey Ellis Arm & Side Chair .....	95
89-051	Wood Top Tabouret Table .....	80	89/91-353/4-R	Harvey Ellis Rocker .....	65
89-052	Tile Top Tabouret Table .....	80	89/91-357	Harvey Ellis Settee .....	61
89-056	Music / Audio Stand .....	83	89/91-360	Highlands Arm & Side Chair .....	96
89-057	Bookshelf Tower .....	83	89/91-367-LC	Compact Spindle Morris Chair .....	62
89/91-058	Floor Lamp .....	129	89/91-369	Spindle Morris Chairs .....	62
89-065	Bracket Clock .....	124	89-376-R	Spindle Rocker .....	65
89-068	Three Glass Mirror .....	123	89-384/6	Spindle Arm & Side Chair .....	96
89/91-073	Harvey Ellis Jewelry Box .....	125	89/91-395	Footstool .....	62
89-080	Roycroft Magazine Pedestal .....	83	89/91-401	Rocker .....	65
89-081	Wedding Mantel Clock .....	124	89/91-406	Bow Arm Morris Chair .....	62
89-083	Small Mantel Clock .....	124	89-409	Westcott Street Library Table .....	118
89/91-084	Bracket Clock .....	124	89-410	Slatted Morris Chair .....	62
89-085	Mantel Clock .....	124	89-411	Commemorative Coffee Table .....	75
89-088	Double Costumer .....	125	89/91-416	Prairie Chair .....	63
89/91-089	Single Costumer .....	125	89-417	Prairie Spindle Chair .....	63
89-095	Gustav Stickley Collector Chest .....	125	89-434	Gus Corner Table .....	77
89-097	Blanket Chest .....	115	89-440	Syracuse Sideboard .....	98
89-098	Mantel Clock .....	125	89/91-447	End Table .....	77
89/91-105	Backless Bar Stool .....	73	89/91-466	Harvey Ellis Organizer .....	118
89-107	Asheville Clock .....	124	89/91-467	Harvey Ellis Fall Front Desk .....	118
89-134	Corner Cabinet .....	98	89/91-468	Harvey Ellis Fall Front Bar .....	101
89-179	Bench .....	86	89/91-470	Harvey Ellis Round Lamp Table .....	77
89-208	Settle .....	58	89-472/3	Harvey Ellis Desk .....	118
89-214	Harvey Ellis Settle .....	58	89/91-475	Harvey Ellis Tea Table .....	77
89/91-220	Prairie Settle .....	58	89-477	Harvey Ellis Fall Front Bookcase .....	118-119
89-234	Prairie Spindle Settle .....	58	89/91-479	Harvey Ellis Round Cocktail Table .....	75



89/91-495	Footstool .....	62	89-664	Round End Table .....	78	89/91-948	Highlands Desk .....	119	89/91-1283	Spindle Library Desk .....	120
89-501	Rectangular End Table .....	77	89/91-672	Harvey Ellis Bed .....	103	89/91-949	Highlands Writing Desk .....	120	89/91-1285	Hi-Lo Desk .....	120
89-504	Tree of Life Pedestal .....	83	89-684	Prairie Bed .....	102	89/91-950	Highlands Mirror .....	123	89-1324	Gus Lounge Chair .....	61
89/91-509	Drop Leaf Table .....	77	89-693	Slat Bed .....	103	89/91-951	Highlands Bench .....	87	89-1324-R	Gus Rocker .....	65
89-510	Gus Commemorative Bookcase .....	84	89/91-705	Single Door Bookcase .....	84	89/91-952	Highlands Bed .....	104	89-1410	Gus Round Lamp Table .....	79
89-515	Octagonal Table .....	77	89/91-706	Harvey Ellis Bookcase .....	84	89/91-953	Highlands Upholstered Bed.....	104	89-1411	Round Table.....	79
89-516	Book Table .....	77	89/91-711	Sideboard .....	98	89/91-954	Highlands Master Chest .....	114	89-1500	Limbert Cafe Chair .....	61
89-532	Soho Footstool .....	61, 75	89/91-713	Round Pedestal Dining Table.....	88	89/91-955	Highlands Pierced Slat Bed .....	104	89-1655/6	Low Bookcase .....	85
89-536	Round Lamp Table .....	78	89-721	Bistro Table .....	101	89/91-956	Highlands Master Dresser .....	114	89-1659	Tall Bookcase .....	85
89/91-537	Harvey Ellis Nesting Tables .....	78	89-729	China Cabinet .....	98	89/91-957	Highlands Low Armoire .....	114	89-1660	Tall Bookcase .....	85
89-545	Cocktail Table .....	75	89-730/731	Writing Desk & Deck with desk .....	119	89/91-958	Highlands 3-Drawer Night Stand .....	114	89-1690	Mobile Bar.....	101
89-546	Gus Tile Top Tabouret .....	80	89/91-743	Harvey Ellis Storage Cocktail Table .....	76	89/91-959	Highlands Door Night Stand .....	114	89/91-1701	Limbert Book Shelf .....	85
89/91-547	Tier Table .....	78	89-744	Harvey Ellis Storage Cocktail Table (SQ) .....	76	89-967	Gus Sideboard.....	99	89-1702	Limbert Open Pedestal .....	129
89/91-555	Small Bookcase (Harvey Ellis) .....	83	89/91-746	End Table .....	78	89/91-970/1	Harvey Ellis Mirror & Mirror No Inlay.....	123	89-1703	Gus Newel Post Lamp .....	129
89/91-556	Large Bookcase (Harvey Ellis) .....	83	89/91-747	Lamp Table .....	78	89/91-980	Highlands Cocktail Table .....	76	89-1706	Lifetime Magazine Rack .....	85
89-562	3-Glass Mirror (Harvey Ellis) .....	123	89/91-756	Three Drawer Cocktail Table .....	76	89/91-981	Highlands Square Cocktail Table .....	76	89/91-1707	Limbert Magazine Stand .....	85
89-563	Secret Looking Glass (Harvey Ellis) .....	123	89-757	Cocktail Table .....	76	89/91-982	Highlands Round Cocktail Table .....	75	89/91-1708	Highlands Gathering Island .....	71
89/91-567	Slatted Back Bookcase .....	83	89-758	Tile Top Cocktail Table .....	76	89/91-983	Highlands Oval End Table.....	79	89-1711	Console Table .....	81
89-576	Butterfly Top End Table .....	78	89-759	Glass Top Cocktail Table .....	76	89/91-984	Highlands End Table.....	79	89/91-1712	Gathering Island-Stone or Wood Top .....	71
89-577	Tile Top End Table .....	78	89/91-761	Display Cabinet .....	98	89/91-986	Highlands Console Table.....	81	89/91-1714	Sofa Table .....	81
89-578	Butterfly Top Cocktail Table .....	75	89-767	Cocktail Table .....	76	89/91-987	Highlands Tabouret.....	80	89/91-1715	Tall Gathering Island-Stone or Wood Top .....	71
89-579	Tile Top Cocktail Table .....	75	89/91-789	Mission Drawtop Dining Table .....	90	89/91-988	Highlands 2-Drawer Chest.....	114	89-1725	Eastwood Footstool.....	61
89-580	Cocktail Table .....	75	89-798	Flip Top Table .....	90	89/91-989-RL	Highlands Recliner.....	60	89-1729	Fall Front Desk.....	121
89-581	Tile Top Cocktail Table .....	75	89-812	Dinner Gong .....	98, 125	89-1005	Gus Tea Table.....	79	89-1730/1/2	Three-Door Buffet & China Tops .....	99
89/91-584	Breakfast Table .....	91	89/91-837-R	Chapel Street Rocker .....	65	89/91-1008	Magazine Rack.....	85	89-1735	Flip Top Harvest Table.....	90
89/91-594	Highlands Round Dining Table .....	89	89/91-846	Harvey Ellis Mirror .....	123	89-1026	Cabinet.....	115	89/91-1737	Highlands Server.....	99
89/91-596	Highlands Pedestal Dining Table .....	89	89/91-847	Harvey Ellis Door Console .....	81	89-1041	Gus Plant Stand.....	79	89/91-1750	Highlands Buffet .....	99
89/91-598	Highlands Trestle Table .....	89	89/91-848	Harvey Ellis Entertainment Console .....	69	89-1046	Etagere .....	85	89/91-1791	Harvey Ellis Sideboard .....	99
89-599	Keyhole Trestle Table .....	91	89/91-857	Sofa Table .....	81	89-1145	Jewelry Chest .....	113	89/91-1792	Harvey Ellis Three-Door Buffet .....	100
89/91-603	Round Tabouret Table .....	80	89-858	Console Table .....	81	89-1150	Sliding Door TV Console .....	69	89/91-1793	Harvey Ellis China Top .....	100
89-605-L/R	Somno Cabinet .....	115	89-859	Two Door Console .....	81	89-1151	Sliding Door TV Console .....	69	89-1794	Harvey Ellis Four-Door Buffet .....	100
89-611	One Drawer Night Stand .....	107	89/91-901	Harvey Ellis Single Dresser .....	110, 112, 114	89/91-1164	Storage Bench .....	87	89-1795	Harvey Ellis China Top.....	100
89-613	Three Drawer Night Stand .....	108	89/91-902	Harvey Ellis Bachelor's Chest .....	108, 110, 112	89-1165	Gus Storage Settle .....	87	89/91-1796	Harvey Ellis Dining Table.....	88
89-614	Three Drawer Chest .....	108	89/91-907	Harvey Ellis Seven Drawer Dresser .....	108, 110, 112	89/91-1170/1/2/3	TV Console.....	66-67	89/91-1797	Harvey Ellis Dining Table.....	88
89-620	Panel Bed .....	102	89/91-908	Harvey Ellis Door Night Stand .....	109, 111, 113	89/91-1175	Large Bridge & Shelf .....	67	89-1799	Argyle Street Bistro Table.....	101
89-625	Triple Dresser .....	107	89/91-909	Open Night Stand .....	109, 111, 113	89/91-1176	Bookcase Unit .....	67	89-1815	Display Cabinet .....	100
89-627	Chest .....	107	89/91-910	Three Drawer Night Stand .....	110, 112, 114	89/91-1178	TV Backboard .....	67	89/91-1818	Mission Display Cabinet .....	100
89-628	Lingerie Chest .....	107	89/91-912	Spindle Bed.....	102	89/91-1180/1/2/3	TV Console .....	66-67	89/91-1820	Highlands Display Cabinet .....	100
89-633	Single Door Bookcase .....	84	89/91-913	Harvey Ellis Nine Drawer Chest.....	108, 110, 112	89/91-1184	Bridge.....	68	89-1830	Grande Trestle Table.....	91
89-637	Master Dresser .....	107	89/91-917	Harvey Ellis Lingerie Chest.....	109, 111, 113	89/91-1185	TV Console .....	68	89-1833	Tall Back Upholstered Arm & Side Chair .....	97
89/91-641	Two Drawer Tall Night Stand .....	115	89/91-918	Cheval Mirror .....	123	89/91-1186	Etagere .....	68	89-1901-E	TV Sideboard .....	69
89-643	Single Bookcase with Glass Door .....	84	89/91-923	Harvey Ellis Tall Chest .....	109, 111, 113	89/91-1187	Highlands Small Entertainment Console .....	68	89-1901	Sideboard .....	100
89-645	Double Bookcase with Glass Doors .....	84	91-924	Sleigh Bed .....	103	89/91-1188	Highlands Entertainment Console .....	68	89-1907	Two Door Display Buffet.....	101
89-647	Triple Bookcase with Glass Doors .....	84	89/91-926	Harvey Ellis High Double Dresser .....	109, 111, 113	89/91-1189	Highlands Entertainment Console .....	69	89-1908	Three Door Display Buffet.....	101
89-660	Library Table.....	119	89/91-927	Harvey Ellis Master Dresser .....	109, 111, 113	89/91-1190/1/2/3	Harvey Ellis TV Console .....	66-67	89-2254	Kneehole Desk.....	121
89-661	Lee Drop Front Desk .....	119	89/91-945	Highlands Low Etagere.....	84	89-1199	Mission Entertainment Console .....	69	89/91-2266/2272	Executive Desk .....	120
89-663	Round Table .....	78	89/91-946	Highlands Etagere.....	84	89-1263	Slat Back Settle .....	59	89/91-2340	Gus Bow Arm Morris Chair .....	63

89/91-2521	Two Drawer File Unit .....	121
89/91-2522	Four Drawer File Unit .....	121
89-2530	File Unit.....	122
89-2531	Door Unit.....	122
89-2532	Keyboard Drawer Unit .....	122
89-2534	Corner Keyboard Drawer.....	122
89-2535	Inside Support.....	122
89-2541	Upper Bookcase with Doors.....	122
89-2550	Upper Corner Unit.....	122
89/91-2586	Computer Work Table .....	121
89/91-2589	Mobile Printer/File Stand.....	121
89-2590	Lounge Chair .....	61
89/91-2591	Footstool .....	61
89-2638	Eastwood Chair .....	61
89-2653	Gus Library Table.....	121
89-7289	Fleming Bar Stool .....	73
91-8725	Glasgow Night Stand w/Lattice .....	115
91-8726	Glasgow Night Stand.....	115
91-8728	Glasgow Platform Bed.....	105
89-8784	Argyle Street End Table.....	79
89/91-8865	Mackintosh Arm & Side Chair .....	97
89-9234	Fayetteville Sofa .....	59
89/91-9236	Orchard St. Sofa .....	59
89/91-9800-CH	Highlands Chair .....	60
89/91-9800-OT	Highlands Ottoman .....	60
89/91-9800	Highlands Sectional .....	59
89/91-9800-88	Highlands Sofa .....	59

**STICKLEY STARTERS**

AN-342	Child's Side Chair.....	149
AN-1330	Child's Rocker.....	149
AN-1640	Child's Table.....	149
AN-1927	Dressing Chest.....	148
AN-1955	Student Hutch.....	151
AN-1956	Student Bookcase .....	149
AN-1970	Twin Bed.....	147
AN-1971	Single Drawer Night Stand.....	148
AN-1972	Dresser.....	148
AN-1973	High Chest.....	148
AN-1975	Mirror.....	151
AN-1976	Bachelor Chest.....	148
AN-1979	Dresser.....	149
AN-1980	Dresser Hutch.....	149
AN-1981	Computer Desk.....	151
AN-1982	Computer Desk Hutch.....	151
AN-1983	Student Desk Chair .....	151
AN-1984	Trundle Bed Unit.....	147
AN-1986	Twin Willow Bed.....	147
AN-1987	Three Drawer Night Stand.....	148
AN-1988	Student Desk.....	151

**PASADENA BUNGALOW**

AN-7301	Fullerton Night Stand.....	143
AN-7302	Inglewood Night Stand.....	143
AN-7303	Burbank Single Dresser.....	143
AN-7304	Huntington Triple Dresser.....	143
AN-7308	Arcadia Vertical Mirror.....	145
AN-7309	Covina Landscape Mirror.....	145
AN-7310	Brookside Tall Chest.....	143
AN-7315	Gamble House Bookcase.....	133
AN-7317	Pasadena Sleigh Bed.....	144
AN-7318	Oak Knoll Display Cabinet.....	133
AN-7320	Tsuba Mirror.....	145
AN-7323	Oak Knoll Open Night Stand.....	144
AN-7326	Spindle Platform Bed.....	144
AN-7327	Oak Knoll Tall Chest.....	144
AN-7328	Oak Knoll Single Dresser.....	144
AN-7329	Oak Knoll Master Dresser.....	144
AN-7330	Tsuba Small Dining Table.....	139
AN-7331	San Gabriel Breakfast Table.....	139
AN-7340	Pasadena Gathering Island.....	133
AN-7342	Pasadena Counter Stool.....	133
AN-7343	Hillcrest Entertainment Console.....	134
AN-7347	Blacker House Shoe Bench.....	134
AN-7350	Gamble House Buffet.....	134
AN-7351	Gamble House China Top.....	134
AN-7353	Blacker House Arm & Side Chair.....	139
AN-7355	East Colorado Arm & Side Chair.....	139
AN-7357/9	Thorsen Round Dining Table.....	140
AN-7361	San Marino Trestle Table.....	140
AN-7365	Oak Knoll Sideboard.....	140
AN-7367	East Colorado Rocker.....	134
AN-7369	Arroyo Storage Tabouret Table.....	134
AN-7378	Sumner Writing Desk.....	145
AN-7381	Tsuba Bustle Back Recliner.....	135
AN-7383	San Gabriel Cocktail Table.....	135
AN-7384	Gamble House Console.....	135
AN-7385	Oak Knoll Cocktail Table.....	136
AN-7386	Oak Knoll End Table.....	136
AN-7387	Tsuba End Table.....	135
AN-7388	San Gabriel End Table.....	135
AN-7389	San Gabriel Sofa Table.....	135
AN-7398-CH	Oak Knoll Chair.....	136
AN-7398-OT	Oak Knoll Ottoman.....	136
AN-7398-90	Oak Knoll Sofa.....	136

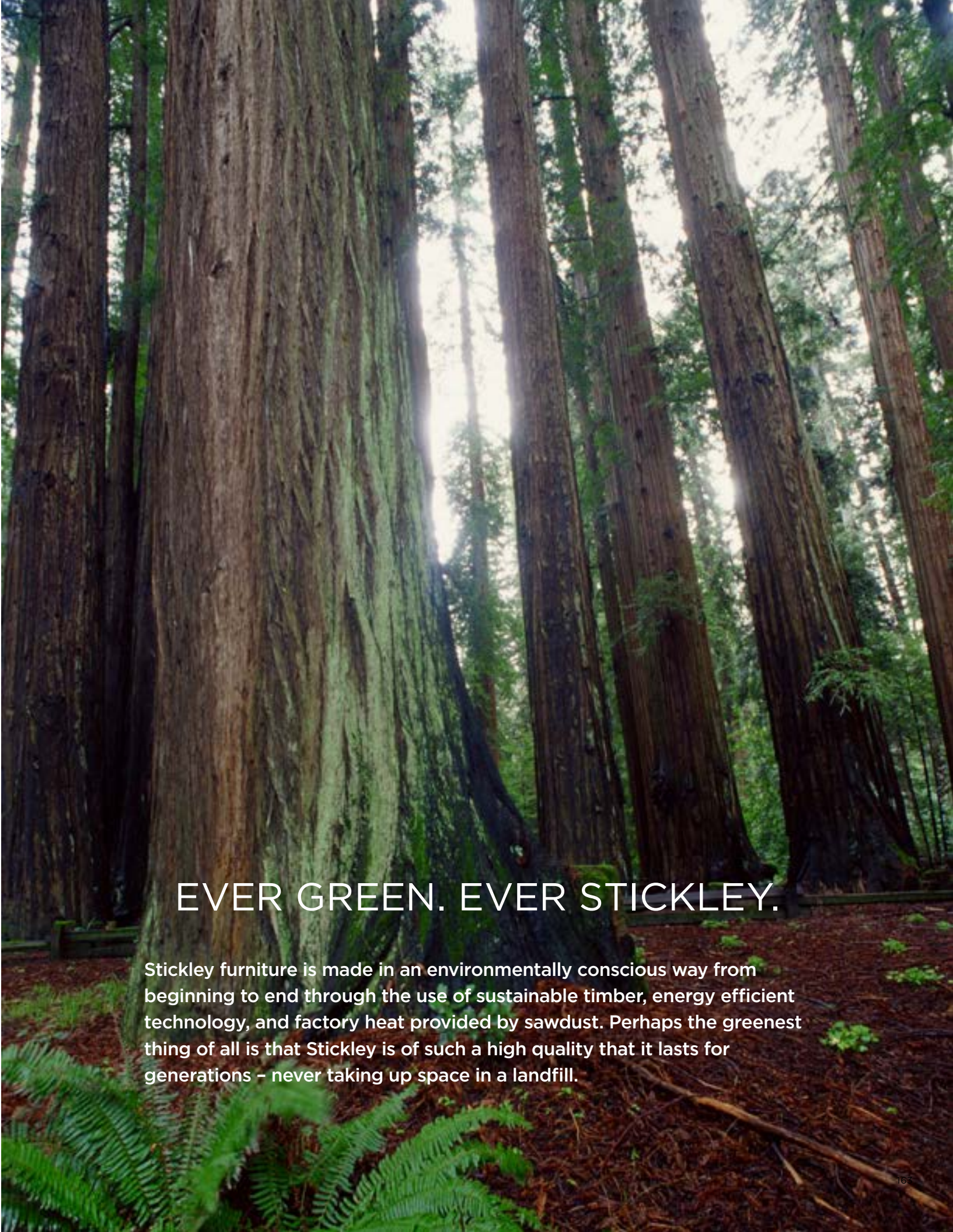

**EVER GREEN. EVER STICKLEY.**

Stickley furniture is made in an environmentally conscious way from beginning to end through the use of sustainable timber, energy efficient technology, and factory heat provided by sawdust. Perhaps the greenest thing of all is that Stickley is of such a high quality that it lasts for generations - never taking up space in a landfill.



# STICKLEY®

L. & J.G. STICKLEY, INC. • P.O. BOX 480, ONE STICKLEY DRIVE • MANLIUS, NEW YORK 13104 • 315.682.5500 • STICKLEY.COM